

**NOTES:**

1. ALL CONSTRUCTION MATERIALS AND WORKMANSHIP SHALL CONFORM TO THE CLARK PUBLIC UTILITIES (CPU) WATER CONSTRUCTION SPECIFICATIONS, STANDARD DETAILS AND THE LATEST EDITION OF THE "STANDARD SPECIFICATIONS FOR ROAD AND BRIDGE CONSTRUCTION" PUBLISHED BY WASHINGTON STATE DEPARTMENT OF TRANSPORTATION (WSDOT).
2. IF THE OPERATING NUT HAS A DEPTH OF 5.0' OR MORE, A VALVE EXTENSION SHALL BE INSTALLED. OPERATING NUT SHALL NOT EXTEND INTO THE ROADWAY BASE ROCK.

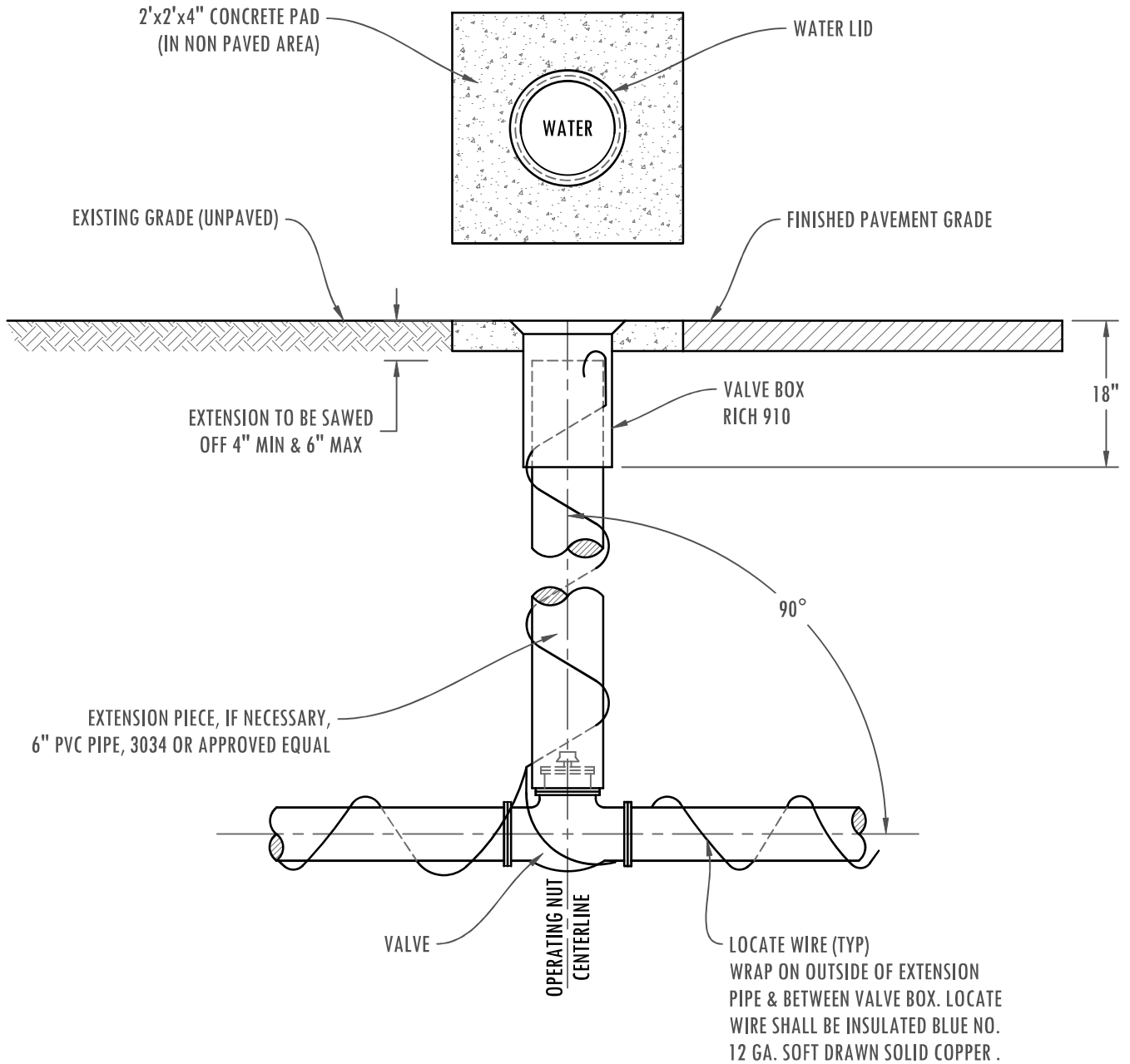

REVISED JANUARY 2025

|           |        |                             |  |
|-----------|--------|-----------------------------|--|
| FILE NAME |        | STANDARD VALVE BOX ASSEMBLY |  |
| 8W        |        |                             |  |
| SHEET     | 1 OF 1 | STANDARD DETAILS            |  |