

NOTES:

1. ALL CONSTRUCTION MATERIALS AND WORKMANSHIP SHALL CONFORM TO THE CLARK PUBLIC UTILITIES (CPU) WATER CONSTRUCTION SPECIFICATIONS, STANDARD DETAILS AND THE LATEST EDITION OF THE "STANDARD SPECIFICATIONS FOR ROAD AND BRIDGE CONSTRUCTION" PUBLISHED BY WASHINGTON STATE DEPARTMENT OF TRANSPORTATION (WSDOT).
2. A CPU WATER UTILITY INSPECTOR SHALL BE AT THE JOB SITE DURING CONSTRUCTION OF ALL WATER FACILITIES. CONTACT 360-992-8022 TWO (2) WORKING DAYS PRIOR TO COMMENCING WORK.
3. WORK WITHIN COUNTY RIGHT-OF-WAY SHALL CONFORM WITH CLARK COUNTY PUBLIC WORKS UTILITY PERMIT REQUIREMENTS AND DETAILS. WORK WITHIN STATE RIGHT-OF-WAY SHALL CONFORM TO WSDOT UTILITY PERMIT REQUIREMENTS AND DETAILS.

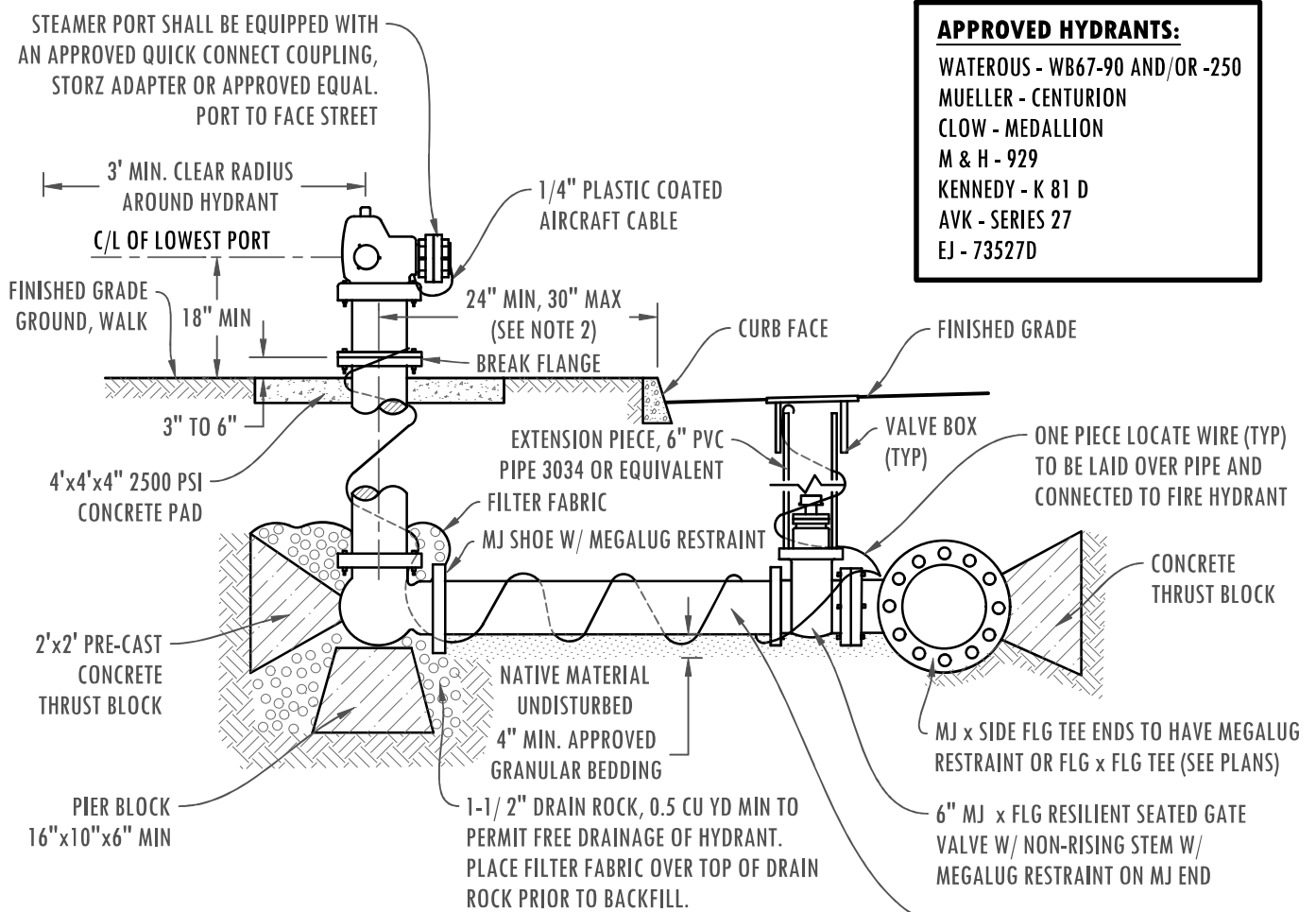

- APPROVED HYDRANTS:**
- WATEROUS - WB67-90 AND/OR -250
 - MUELLER - CENTURION
 - CLOW - MEDALLION
 - M & H - 929
 - KENNEDY - K 81 D
 - AVK - SERIES 27
 - EJ - 73527D

FIRE HYDRANT NOTES:

1. FIRE HYDRANT INSTALLATIONS SHALL BE INSPECTED PRIOR TO BACKFILLING.
2. WHERE HYDRANTS ARE SET BEHIND SIDEWALK, DISTANCE FROM BACK OF SIDEWALK TO HYDRANT C/L SHALL BE 18" MIN., 24" MAX.
3. FIRE HYDRANTS SHALL BE SHOP PAINTED PRIOR TO INSTALLATION W/ STANDARD A.W.W.A, GLOSS B, YELLOW
4. NO DOMESTIC OR FIRE PROTECTION SERVICE SHALL BE TAPPED OFF OF THE FIRE HYDRANT PIPING.
5. FIRE HYDRANT MAINS SHALL BE 8" MIN. A 6" MAIN CAN BE USED FOR A DEAD-END RUN OF LESS THAN 50' TO A FIRE HYDRANT SUBJECT TO ADEQUATE FIRE FLOW.
6. THE LOCATION OF THE UTILITIES SHALL BE VERIFIED IN ADVANCE TO ALLOW FOR ALIGNMENT ADJUSTMENTS. CALL UTILITY LOCATES TWO (2) WORKING DAYS PRIOR TO CONSTRUCTION (1-800-553-4344).
7. LOCATE WIRE SHALL BE INSULATED BLUE, NO. 12 GA. SOFT DRAWN SOLID COPPER.

6" DI PIPE W/ MEGALUG RESTRAINTS. USE ONE SECTION OF PIPE FOR LENGTHS LESS THAN 18'. FOR LENGTHS GREATER THAN 18' USE A CPU APPROVED MECHANICAL RESTRAINT AT ALL PIPE JOINTS

REVISED JANUARY 2025

FILE NAME		STANDARD FIRE HYDRANT ASSEMBLY	
7W			
SHEET	1 OF 1	STANDARD DETAILS	