

THRUST BLOCK NOTES:

1. CAST IN PLACE BLOCKING SHALL BE POURED WITHOUT DIRECT CONTACT TO THE PIPE OR FITTINGS.
2. PROTECTIVE MATERIAL SUCH AS PLASTIC OR APPROVED EQUAL SHALL BE PLACED BETWEEN THE CONCRETE AND PIPE OR FITTING.
3. BLOCKING SHALL BE DESIGNED FOR STATIC PRESSURE OF 200 PSI OR 1.5 TIMES THE WORKING PRESSURE, WHICHEVER IS GREATER.
4. CAST IN PLACE BLOCKING SHALL BE POURED AGAINST FIRM UNDISTURBED SOIL WITH MINIMUM BEARING PRESSURE OF 2,000 LB/SQ.FT.
5. CONCRETE FOR ALL BLOCKING SHALL HAVE A 28-DAY MINIMUM COMPRESSIVE STRENGTH OF 2,500 PSI.
6. CONCRETE BLOCKING FOR VERTICAL BENDS SHALL REQUIRE SITE SPECIFIC ENGINEERING DESIGN.
7. LAYOUT TO BE APPROVED BY THE INSPECTOR PRIOR TO AND AFTER CONCRETE PLACEMENT.
8. ALL THRUST BLOCKS SHALL BE PLACED IN CENTER OF TEE OR BEND.
9. THESE DETAILS IN NO WAY LIMIT THE SIZE OR LOCATION OF ADDITIONAL BLOCKING WHEN REQUESTED BY THE UTILITY.
10. THRUST BLOCKS ON WATER MAINS AND FITTINGS 12" OR LARGER SHALL BE DESIGNED BY A PROFESSIONAL ENGINEER AND APPROVED BY CLARK PUBLIC UTILITIES PRIOR TO CONSTRUCTION.

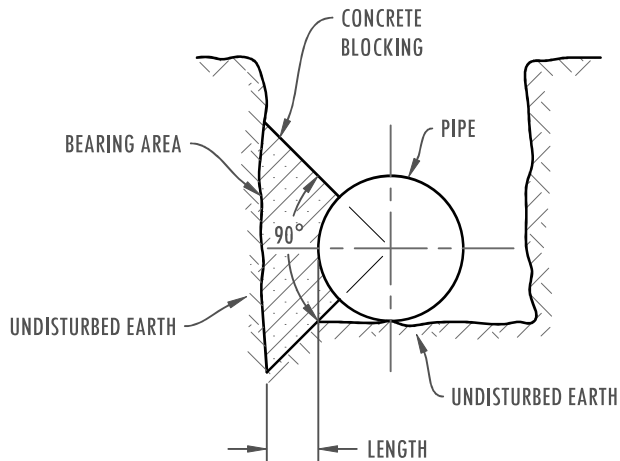

PIPE SIZE	HORIZ. FITTINGS (BENDS)	BEARING AREA (SF)	MINIMUM BLOCK SIZE (FT.)	MINIMUM LENGTH OF BLOCKING (FT.-IN.)
4"	TEE	1.9	1.5' x 1.5'	0'-6"
	90°	2.7	2.0' x 2.0'	0'-6"
	45°	1.4	1.5' x 1.5'	0'-6"
	22-1/2°	0.7	1.5' x 1.5'	0'-6"
6"	TEE	2.8	2.0' x 2.0'	0'-6"
	90°	4.0	2.0' x 2.0'	0'-6"
	45°	2.2	1.5' x 1.5'	0'-6"
	22-1/2°	1.1	1.5' x 1.5'	0'-6"
8"	TEE	5.0	2.0' x 3.0'	0'-8"
	90°	7.1	3.0' x 4.0'	0'-8"
	45°	3.8	2.0' x 2.0'	0'-6"
	22-1/2°	2.0	1.5' x 1.5'	0'-6"
10"	TEE	7.9	3.0' x 4.0'	0'-8"
	90°	11.1	3.0' x 4.0'	0'-8"
	45°	6.0	3.0' x 4.0'	0'-8"
	22-1/2°	3.1	2.0' x 2.0'	0'-6"
12"	TEE	11.3	3.0' x 4.0'	0'-8"
	90°	16.0	4.0' x 4.0'	1'-0"
	45°	8.7	3.0' x 4.0'	0'-8"
	22-1/2°	4.4	2.0' x 3.0'	0'-8"
	11-1/4°	3.3	2.0' x 2.0'	0'-6"

TABLE ASSUMES SOIL BEARING OF 2,000 LB/SQ.FT AND DESIGN WORKING PRESSURE OF 200 PSI

REVISED JANUARY 2025

FILE NAME		THRUST BLOCK	
5W			
SHEET	1 OF 1	STANDARD DETAILS	