

1. PIPE FITTINGS SHALL BE DUCTILE IRON AND SHALL CONFORM TO AWWA STANDARD C110. DUCTILE IRON (COMPACT) FITTINGS CONFORMING TO AWWA STANDARD C153 MAY BE SUBSTITUTED IN LIEU OF AWWA C110 FITTINGS FOR FITTING SIZES 3-INCHES THROUGH 24-INCHES IN DIAMETER. FITTINGS SHALL BE MECHANICAL JOINT OR FLANGED AS REQUIRED AND SHOWN ON THE PLANS.
2. DUCTILE IRON MECHANICAL JOINT FITTINGS SHALL BE PRESSURE RATED FOR 350 PSI. DUCTILE IRON FLANGED JOINT FITTINGS SHALL BE PRESSURE RATED FOR 250 PSI.
3. FITTINGS SHALL BE MORTAR LINED AND SEAL COATED.
4. DUCTILE IRON SLEEVES SHALL BE OF THE LONG BODY DESIGN AND BOTH ENDS MECHANICAL JOINT.
5. GASKETS FOR FLANGED JOINTS SHALL BE 1/8" THICK, FULL FACED WITH AT LEAST (3) BULB TYPE RIBS MOLDED INTO BOTH FACES.
6. MECHANICAL JOINT GASKETS SHALL BE STANDARD STYRENE BUTADIENE RUBBER (SBR) GASKETS
7. BOLTS AND NUTS SHALL BE CARBON STEEL AND SHALL CONFORM TO THE REQUIREMENTS OF ASTM A307 OR ASTM A193 GRADE B7 WITH ASTM A194 GRADE 2H HEAVY HEX NUTS.
8. GATE VALVES (4" TO 8") - GATE VALVES FOR BURIED SERVICE SHALL BE THE RESILIENT-SEAT TYPE, WITH AN IRON BODY, NON-RISING STEM, BOLTED BONNET, LEFT OPENING AND SHALL CONFORM TO AWWA STANDARD C509 AND C515. THE WEDGE SHALL BE TOTALLY ENCAPSULATED WITH RUBBER. ALL GATE VALVES SHALL BE RATED AT 250 PSI FOR AWWA SERVICE. THE INTERIOR AND EXTERIOR SHALL BE FUSION-BONDED EPOXY AND ALL COATINGS AND/OR LININGS SHALL CONFORM TO AWWA STANDARD C550 AND SHALL BE SUITABLE FOR POTABLE WATER SERVICE AND NSF CERTIFIED.
9. BUTTERFLY VALVES (10" AND LARGER) - BUTTERFLY VALVES SHALL BE SHORT BODY CLASS 250 VALVES CONFORMING TO THE REQUIREMENTS OF AWWA STANDARD C504. BUTTERFLY VALVES SHALL BE RUBBER SEATED AND TIGHT CLOSING. VALVE BODIES SHALL BE HIGH STRENGTH CAST IRON OR HIGH STRENGTH DUCTILE IRON. VALVE INTERIOR AND EXTERIOR SURFACES SHALL BE COATED WITH EPOXY IN ACCORDANCE WITH AWWA C504 AND SHALL BE SUITABLE FOR POTABLE WATER SERVICE AND NSF 61 CERTIFIED.
10. THREE VALVES SHALL BE PLACED AT EVERY TEE, AND FOUR VALVES SHALL BE PLACED AT EVERY CROSSING, UNLESS OTHERWISE DIRECTED BY THE CPU INSPECTOR.
11. A MINIMUM DISTANCE OF 1,000 FEET BETWEEN VALVES ON ALL TRANSMISSION AND DISTRIBUTION MAINS.
12. VALVE SHALL BE 2" SQUARE OPERATING NUT.

REVISED JANUARY 2025

FILE NAME		FITTING & VALVE SPECIFICATIONS	
0-FV			
SHEET	1 OF 1	STANDARD DETAILS	

GENERAL INSTALLATION NOTES:

1. INSTALL WATER MAIN WITH 3.0 FEET OF MINIMUM COVER UNLESS OTHERWISE NOTED. DEPTH MAY INCREASE AT UTILITY AND CULVERT CROSSINGS.
2. LOCATE WIRE SHALL BE COATED (BLUE INSULATED), NO. 14 GA. SOFT DRAWN SOLID COPPER. USE WATERPROOF CONNECTORS AT ALL WIRE SPLICES.
3. NEW AND REPAIRED WATER MAINS SHALL BE DISINFECTED PER AWWA C651 PRIOR TO BEING PLACED INTO SERVICE. CONNECTION TO AN EXISTING WATER MAIN MAY ONLY BE DONE AFTER PROPER DISINFECTION, TESTING, FLUSHING AND APPROVAL BY CPU.
4. WHENEVER A PIPE IS CUT AND NOT RECONNECTED, THE CUT ENDS SHALL BE GROUT FILLED OR REMOVED, AS DIRECTED BY THE CPU INSPECTOR. PUBLIC WATER FACILITIES WITHIN THE PUBLIC RIGHT-OF-WAY SCHEDULED TO BE ABANDONED SHALL BE FILL WITH AN APPROVED CDF SLURRY AND CAPPED AT BOTH ENDS. REFER TO THE GOVERNING BODY FOR GROUT FILLING SPECIFICATIONS. ALL VALVE BOX TOPS ASSOCIATED WITH THE ABANDONED WATER LINES SHALL BE REMOVED AND FILLED WITH CONTROLLED DENSITY (CDF) OR CONCRETE.
5. WATER MAINS BEING INSTALLED NEAR TELEPHONE/CABLE COMMUNICATIONS SHALL HAVE A MINIMUM 12" HORIZONTAL AND 6" VERTICAL CLEARANCE.
6. WATER MAINS BEING INSTALLED NEAR UNDERGROUND ELECTRICAL LINES SHALL HAVE A MINIMUM 60" HORIZONTAL AND 6" VERTICAL CLEARANCE.
7. REQUIRED SEPARATION BETWEEN WATER LINES AND SANITARY SEWER LINES SHALL BE AS FOLLOWS:

HORIZONTAL SEPARATIONS (PARALLEL)

A MINIMUM SEPARATION OF TEN (10) FEET (MEASURED EDGE TO EDGE) BETWEEN SANITARY SEWER LINES AND WATER LINES SHALL BE MAINTAINED WHENEVER POSSIBLE. WHEN CONDITIONS PREVENT THE MINIMUM TEN (10) FOOT HORIZONTAL SEPARATION THE ENGINEER SHALL BE NOTIFIED.

VERTICAL SEPARATION (PERPENDICULAR)

WATER LINES CROSSING SANITARY SEWER LINES SHALL BE LAID ABOVE THE SEWER LINES TO PROVIDE A SEPARATION OF AT LEAST 18" BETWEEN THE INVERT OF THE WATER PIPE AND THE CROWN OF THE SANITARY SEWER PIPE. A LENGTH OF WATER PIPE SHALL BE CENTERED AT THE POINT OF CROSSING AND SHALL BE THE LONGEST STANDARD LENGTH AVAILABLE FROM THE MANUFACTURER.

8. REQUIRED SEPARATION BETWEEN WATER LINES AND UNDERGROUND PRIMARY ELECTRICAL LINES SHALL BE AS FOLLOWS:

HORIZONTAL SEPARATIONS (PARALLEL)

A MINIMUM SEPARATION OF FIVE (5) FEET (MEASURED EDGE TO EDGE) BETWEEN UNDERGROUND ELECTRICAL LINES AND WATER LINES SHALL BE MAINTAINED WHENEVER POSSIBLE. WHEN CONDITIONS PREVENT THE MINIMUM FIVE (5) FOOT HORIZONTAL SEPARATION THE ENGINEER SHALL BE NOTIFIED.

VERTICAL SEPARATION (PERPENDICULAR)

WATER LINES CROSSING UNDERGROUND ELECTRICAL LINES SHALL BE LAID ABOVE THE ELECTRICAL LINES TO PROVIDE A SEPARATION OF AT LEAST 12" BETWEEN THE INVERT OF THE WATER PIPE AND THE CROWN OF THE UNDERGROUND ELECTRICAL LINE.

9. THE CONTRACTOR SHALL USE CONSTRUCTION METHODS THAT PROTECT THE PIPE INTERIORS, FITTINGS AND VALVES AGAINST CONTAMINATION.
10. ANY PIPE, FITTINGS OR VALVES THAT CANNOT BE DISINFECTED WITH THE MAIN LINE BY CHLORINE FOR 24 HOURS SHALL HAVE THE INTERIORS SWABBED WITH A 1% HYPOCHLORITE SOLUTION BEFORE INSTALLATION.
11. CONCRETE THRUST BLOCKS SHALL BE CONSTRUCTED AT ALL TEES, BENDS, DEAD ENDS AND WHERE INDICATED ON THE PLANS.
12. ALL MJ FITTINGS SHALL BE RESTRAINED USING MJ MECHANICAL RESTRAINT FOLLOWER GLANDS APPROPRIATE FOR THE PIPE MATERIAL.
13. 6" WATER PIPE LEADING TO FIRE HYDRANTS SHALL BE DIP AND SHALL BE ONE CONTINUOUS PIECE OF PIPE. IF THE RUN IS LONGER THAN ONE PIECE OF PIPE, THEN ALL PIPE JOINTS SHALL BE MECHANICALLY RESTRAINED WITH "FIELD-LOK" GASKETS OR OTHER CPU APPROVED RESTRAINTS
14. ALL PIPE GREATER THAN 12" SHALL BE FULLY RESTRAINED DUCTILE IRON PIPE
15. IF 3 OR MORE LOTS ARE IN A FLAG LOT, AN EXTENSION OF THE MAIN SHALL BE REQUIRED.

REVISED JANUARY 2025

FILE NAME		GENERAL INSTALLATION NOTES	
0-GI			
SHEET	1 OF 1	STANDARD DETAILS	

GENERAL NOTES:

1. ALL CONSTRUCTION MATERIALS AND WORKMANSHIP SHALL CONFORM TO THE CLARK PUBLIC UTILITIES (CPU) WATER CONSTRUCTION SPECIFICATIONS, STANDARD DETAILS AND THE MOST CURRENT EDITION OF THE "STANDARD SPECIFICATIONS FOR ROAD AND BRIDGE CONSTRUCTION" PUBLISHED BY WASHINGTON STATE DEPARTMENT OF TRANSPORTATION (WSDOT).
2. A CPU WATER UTILITY INSPECTOR SHALL BE AT THE JOB SITE DURING AND APPROVE CONSTRUCTION OF ALL WATER FACILITIES PRIOR TO BACKFILLING. CONTACT 360-992-8022 TWO WORKING DAYS PRIOR TO COMMENCING WORK.
3. WORK WITHIN COUNTY RIGHT-OF-WAY SHALL CONFORM WITH CLARK COUNTY PUBLIC WORKS UTILITY PERMIT REQUIREMENTS AND DETAILS. WORK WITHIN STATE RIGHT-OF-WAY SHALL CONFORM TO WSDOT UTILITY PERMIT REQUIREMENTS AND DETAILS.
4. THE LOCATION OF THE UTILITIES SHALL BE VERIFIED IN ADVANCE TO ALLOW FOR ALIGNMENT ADJUSTMENTS. THE LOCATIONS OF ALL EXISTING UTILITIES ARE FOR INFORMATIONAL PURPOSES ONLY. MANY LOCATIONS ARE PER SCHEMATIC RECORD DRAWINGS. THE CURRENT AND EXACT LOCATIONS OF FACILITIES MUST BE VERIFIED PRIOR TO CONSTRUCTION. THE CONTRACTOR PERFORMING THE WORK SHALL COMPLY WITH THE PROVISIONS OF FACILITIES AT LEAST 48 BUSINESS DAY HOURS PRIOR TO EXCAVATION. CALL 811 FOR UTILITY LOCATE SERVICE.
5. ONLY TAPPING COMPANIES APPROVED BY CLARK PUBLIC UTILITIES SHALL BE USED TO MAKE ALL TAPS.
6. ACTUAL ROAD ALIGNMENTS MAY VARY FROM RIGHT-OF-WAY INDICATED. THE CONTRACTOR SHALL VERIFY THE PROPOSED PIPE ALIGNMENT AND REPORT DIFFERENCES TO THE CPU INSPECTOR. ALL ALIGNMENT CHANGES MUST BE APPROVED BY THE CPU INSPECTOR PRIOR TO INSTALLATION.
7. DRIVEWAYS DISTURBED BY CONSTRUCTION SHALL BE RESTORED BY THE CONTRACTOR TO "LIKE" OR BETTER CONDITION. REFER TO PLAN FOR APPROXIMATE LOCATIONS AND TYPES.
8. CONTRACTOR SHALL VERIFY EXISTING UTILITY CULVERTS, CONDUITS AND LINE LOCATION PRIOR TO CONSTRUCTION. DUE TO FIELD CONDITIONS, THE CONTRACTOR SHALL FIELD ADJUST THE VERTICAL AND HORIZONTAL ALIGNMENT OF THE WATER MAIN TO CLEAR THE UTILITY IN CONFLICT AND PROVIDE THE MIN. 3.0 FEET OF COVER AS APPROVED BY THE CPU INSPECTOR. ALL CULVERTS WHICH ARE DISTURBED BY CONSTRUCTION SHALL BE RESTORED BY THE CONTRACTOR IN ACCORDANCE WITH THE SPECIFICATIONS.
9. FENCES DISTURBED BY CONSTRUCTION SHALL BE RESTORED OR REPLACED BY THE CONTRACTOR TO "LIKE" OR BETTER CONDITION.
10. CONTRACTOR SHALL VERIFY EXISTING SIGN AND MAILBOX LOCATIONS PRIOR TO CONSTRUCTION. SIGNS & MAILBOXES THAT ARE DISTURBED BY CONSTRUCTION SHALL BE RELOCATED BACK FROM EDGE OF PAVEMENT, 1.0 FEET CLEAR OF WATER MAIN. ANY SIGNS OR MAILBOXES DAMAGED SHALL BE REPAIRED OR REPLACED AS PER THE SPECIFICATIONS.
11. THE WATER FACILITIES SHALL BECOME THE PROPERTY OF CLARK PUBLIC UTILITIES AFTER A SATISFACTORY BACTERIA AND PRESSURE TEST HAVE BEEN PERFORMED BY THE UTILITY. ALL MATERIALS AND WORKMANSHIP ARE SUBJECT TO A ONE YEAR WARRANTY, COMMENCING AT ACCEPTANCE OF FINAL ACCEPTANCE LETTER. REPLACEMENT AND/OR REPAIRS OF DEFECTIVE MATERIALS SHALL BE THE DEVELOPERS/OWNERS RESPONSIBILITY.
12. WHEN ASBESTOS CONCRETE PIPE IS ENCOUNTERED, THE CONTRACTOR SHALL SUPPLY WORKERS WHO ARE CERTIFIED TO WORK ON ASBESTOS CONCRETE PIPE AND SHALL FOLLOW ALL REGULATORY REQUIREMENTS.
13. THE CONTRACTOR SHALL TRANSFER AND/OR ABANDON EXISTING SERVICES AS DIRECTED BY THE INSPECTOR.
14. THE INSTALLED WATER MAIN SHALL BE PRESSURE TESTED AT A MINIMUM OF 200 PSI OR 1.5 TIMES THE WORKING PRESSURE, WHICHEVER IS GREATER FOR 1 HOUR. THE TEST WILL BE PERFORMED BY THE CLARK PUBLIC UTILITIES INSPECTOR. THE CONTRACTOR SHALL PROVIDE ASSISTANCE AS NEEDED.
15. THE INSTALLED WATER MAIN SHALL BE THOROUGHLY DISINFECTED AND FLUSHED IN ACCORDANCE WITH THE CLARK PUBLIC UTILITIES STANDARDS AND REQUIREMENTS. ONLY CLARK PUBLIC UTILITIES EMPLOYEES ARE PERMITTED TO FILL AND FLUSH THE WATER MAIN. THE CONTRACTOR SHALL PROVIDE ASSISTANCE AS NEEDED. IN AREAS WHERE THE DE-CHLORINATION OF FLUSHED WATER IS NOT POSSIBLE, THE CONTRACTOR SHALL PROVIDE WATER TRUCKS TO FLUSH INTO. ALL FLUSHING SHALL BE IN ACCORDANCE WITH AWWA C651 DISINFECTION STANDARDS.
16. PRIOR TO ACCEPTING THE SYSTEM OR ALLOWING THE MAIN TO BE PUT IN SERVICE, A WATER SAMPLE SHALL BE TAKEN BY THE CLARK PUBLIC UTILITIES INSPECTOR AND A TEST PERFORMED BY AN ACCREDITED LAB TO INSURE NO HAZARD EXISTS.

REVISED JANUARY 2025

FILE NAME		GENERAL NOTES	
0-GN			
SHEET	1 OF 1	STANDARD DETAILS	

MECHANICAL JOINT RESTRAINT SPECIFICATIONS

- 1. MECHANICAL JOINT RESTRAINT SHALL BE ACCOMPLISHED BY A RESTRAINT DEVICE CONSISTING OF A FOLLOWER GLAND UTILIZING MULTIPLE GRIPPING WEDGES. GLAND BODY AND WEDGES SHALL BE DUCTILE IRON AND EPOXY COATED.
- 2. T-BOLTS AND NUTS SHALL BE HIGH STRENGTH LOW ALLOY STEEL T-BOLTS AND STEEL SHALL MEET AWWA C111 COMPOSITION SPECIFICATIONS.
- 3. RESTRAINT GLAND SHALL UTILIZE A STANDARD MECHANICAL JOINT GASKET.
- 4. THE FOLLOWING IS THE APPROVED LIST OF RESTRAINED JOINT SYSTEMS FOR MECHANICAL JOINTS AND DIP:
 - 4.1 "ROMAGRIP", ROMAC INDUSTRIES.
 - 4.2 "SERIES 1000 TUFGRIP", TYLER UNION.
 - 4.3 "MEGALUG", EBAA IRON, INC.
 - 4.4 "STARGRIP SERIES 3000", STAR PIPE PRODUCT
 - 4.5 "SIGMA ONE-LOK", OR
 - 4.6 APPROVED EQUIVALENT
- 5. THE FOLLOWING IS THE APPROVED LIST OF RESTRAINED JOINT SYSTEMS FOR MECHANICAL JOINTS AND PVC:
 - 5.1 "ROMAGRIP FOR PVC", ROMAC INDUSTRIES.
 - 5.2 "SERIES 2000 FOR PVC TUFGRIP", TYLER UNION.
 - 5.3 "MEGALUG SERIES 2000 PV", EBAA IRON, INC.
 - 5.4 APPROVED EQUIVALENT

DUCTILE IRON PIPE RESTRAINED JOINT SPECIFICATIONS

- 1. PIPE JOINT RESTRAINT FOR DIP SHALL BE ACCOMPLISHED WITH A PIPE BELL/SPIGOT INTEGRAL LOCK MECHANISM.
- 2. AS AN ALTERNATIVE AND WHERE ALLOWED BY CLARK PUBLIC UTILITIES, A BOLTLESS RESTRAINING GASKETS FOR DIP TYTON JOINT STYLE PIPE MAY BE USED. THE RESTRAINT GASKET SHALL BE A BOLTLESS GASKET WITH INTEGRAL RESTRAINING SYSTEM UTILIZING STAINLESS STEEL PARTS AND SHALL BE PRESSURE RATED FOR 350 PSI. THE GASKETS SHALL BE IN CONFORMANCE WITH ANSI/AWWA C111/A21.11 AND CERTIFIED TO NSF/ANSI 61. THE FOLLOWING IS THE APPROVED LIST OF DIP PIPE JOINT RESTRAINED GASKET SYSTEMS:
 - 2.1 "FIELD LOK 350 GASKET", U.S. PIPE AND FOUNDRY CO.
 - 2.2 "GRIPPER GASKET" (WITH TYTON JOINT), GRIPPER GASKET LLC.
 - 2.3 "McWANE DUCTILE SURE STOP GASKETS (WITH TYTON JOINT)
 - 2.4 "AMERICAN FAST-GRIP GASKET" (WITH FASTITE JOINT)
 - 2.5 "FLEX-RING JOINT PIPE", AMERICAN
 - 2.6 "TR FLEX JOINT PIPE", US PIPE
 - 2.7 "HDSS JOINT PIPE", US PIPE
 - 2.8 APPROVED EQUIVALENT

PVC PIPE RESTRAINED JOINT SPECIFICATIONS

- 1. PVC PIPE JOINT RESTRAINT FOR MAY BE ACCOMPLISHED BY UTILIZING A PROPRIETARY PVC PIPE WHICH UTILIZES A PIPE BELL/SPIGOT INTEGRAL JOINT RESTRAINT MECHANISM. THE FOLLOWING IS THE APPROVED LIST OF PROPRIETARY PVC C-900 PIPE JOINT RESTRAINED SYSTEMS:
 - 1.1 "EAGLE LOC 900", JM EAGLE
 - 1.2 "CERTA-LOK C900/RJ", CERTAINTEED
 - 1.3 "DIAMOND LOK-21", DIAMOND PLASTICS INC.
 - 1.4 "RIEBERLOK" GASKET
 - 1.5 APPROVED EQUIVALENT
- 2. AS AN ALTERNATIVE, PVC PIPE MAY BE COUPLED TO CREATE A RESTRAINED JOINT BY UTILIZING A DUCTILE IRON MECHANICAL JOINT LONG PATTERN SLEEVE WITH A RESTRAINT FOLLOWER GLAND UTILIZING MULTIPLE GRIPPING WEDGES.

REVISED JANUARY 2025

FILE NAME		MECHANICAL JOINT & PIPE JOINT RESTRAINT SPECIFICATIONS	
O-MJ			
SHEET	1 OF 1	STANDARD DETAILS	

EXISTING WATER SERVICES:

THE CONTRACTOR SHALL TRANSFER, MOVE AND/OR ABANDON EXISTING WATER SERVICES AS DIRECTED BY THE CLARK PUBLIC UTILITIES INSPECTOR.

1. EXISTING WATER SERVICES TO BE ABANDONED SHALL BE EXCAVATED TO THE CORP, A 12" SECTION TO BE REMOVED AND BOTH ENDS TO BE CAPPED. STOP AT THE WATER MAIN AND THE CORP STOP SHALL BE CLOSED. THE METER BOX SHALL BE REMOVED AND THE WATER SERVICE LINE CAN BE ABANDONED IN PLACE. THE EXISTING METER SHALL BE RETURNED TO CLARK PUBLIC UTILITIES WATER DEPT. ROAD REPAIR SHALL BE AS REQUIRED BY THE CLARK COUNTY RIGHT OF WAY PERMIT REQUIREMENTS.
2. WHEN AN EXISTING WATER SERVICE IS TO BE MOVED, THE CONTRACTOR SHALL EXPOSE A PORTION OF THE EXISTING WATER SERVICE SO THAT THE CLARK PUBLIC UTILITIES INSPECTOR CAN EVALUATE THE MATERIAL SIZE AND CONDITION OF THE EXISTING WATER SERVICE LINE.

THE INSPECTOR WILL DETERMINE WHETHER THE WATER SERVICE LINE CAN BE EXTENDED OR SHORTENED. IF THE INSPECTOR DETERMINES THE EXISTING WATER SERVICE LINE IS SUBSTANDARD, THEN A NEW POLYETHYLENE (PE) SERVICE LINE SHALL BE INSTALLED FROM THE WATER MAIN (MINIMUM SIZE 1" DIA).

ALL EXISTING WATER SERVICE LINES THAT ARE LESS THAN 1" DIAMETER SHALL BE CONSIDERED SUBSTANDARD AND SHALL BE REPLACED WITH A NEW WATER SERVICE LINE PER CLARK PUBLIC UTILITIES STANDARDS.

MAIN LINE PIPE MATERIAL:

UNLESS OTHERWISE STATED ON THE PLAN, ALL MAIN LINE PIPE SHALL BE EITHER DUCTILE IRON PIPE (DIP), MANUFACTURED IN THE USA, OR POLYVINYL CHLORIDE PIPE (PVC). ALL PIPE SHALL BE SUITABLE FOR POTABLE WATER SERVICE IN ACCORDANCE WITH ANSI/NSF 61 STANDARDS.

- A. DUCTILE IRON PIPE SHALL CONFORM TO ANSI A21.51 OR AWWA C151. USE PUSH-ON JOINTS EXCEPT WHERE OTHER JOINT TYPES ARE NOTED ON THE CONTRACT DRAWINGS. UNLESS SPECIFICALLY NOTED ON THE CONTRACT DRAWINGS, 3"-12" PIPE SHALL BE PRESSURE CLASS 52 AND PIPE SIZES GREATER THAN 12" DIAMETER SHALL BE THICKNESS CLASS 52.
- B. POLYVINYL CHLORIDE (PVC) PRESSURE PIPE (4"-30"). USE UN-PLASTICIZED PVC PLASTIC PIPE WITH INTEGRAL BELL AND SPIGOT JOINTS. USE PUSH-ON JOINTS EXCEPT WHERE OTHER JOINT TYPES ARE NOTED ON THE CONTRACT DRAWINGS. PIPE SHALL MEET THE REQUIREMENTS OF DR 18, UNLESS OTHERWISE NOTED ON THE DRAWING. UNLESS SPECIFICALLY NOTED ON THE CONTRACT DRAWINGS, 4"-12" PIPE SHALL MEET THE REQUIREMENTS OF AWWA C900 AND 14"-30" PIPE SHALL MEET THE REQUIREMENTS OF AWWA C905.
- C. WHEN HIGH-DENSITY POLYETHYLENE PIPE (HDPE) IS REQUIRED OR ALLOWED IT SHALL BE BLACK WITH A MINIMUM OF TWO EQUALLY SPACED BLUE COLORED STRIPES EXTRUDED INTO THE OUTER SHELL IN CONFORMANCE WITH THE UNIFORM COLOR CODE (UCC). UNLESS OTHERWISE NOTED ON THE DRAWINGS, PIPE SHALL BE IRON PIPE SIZE (IPS) AND HAVE A WALL-THICKNESS DIMENSION RATIO (DR) OF 9. LARGE DIAMETER PIPE (4"-65") PIPE SHALL CONFORM TO ANSI/AWWA C906.

REVISED JANUARY 2025

FILE NAME		MAIN LINE PIPE MATERIAL & EXISTING WATER SERVICE NOTES	
0-PM			
SHEET	1 OF 1	STANDARD DETAILS	

NOTES:

1. ALL CONSTRUCTION MATERIALS AND WORKMANSHIP SHALL CONFORM TO THE CLARK PUBLIC UTILITIES (CPU) WATER CONSTRUCTION SPECIFICATIONS, STANDARD DETAILS AND THE LATEST EDITION OF THE "STANDARD SPECIFICATIONS FOR ROAD AND BRIDGE CONSTRUCTION" PUBLISHED BY WASHINGTON STATE DEPARTMENT OF TRANSPORTATION (WSDOT).
2. A WATER UTILITY INSPECTOR SHALL BE AT THE JOB SITE DURING CONSTRUCTION OF ALL WATER FACILITIES. CONTACT 360-992-8022 TWO (2) WORKING DAYS PRIOR TO COMMENCING WORK.
3. WORK WITHIN COUNTY RIGHT-OF-WAY SHALL CONFORM WITH CLARK COUNTY PUBLIC WORKS UTILITY PERMIT REQUIREMENTS AND DETAILS. WORK WITHIN STATE RIGHT-OF-WAY SHALL CONFORM TO WSDOT UTILITY PERMIT REQUIREMENTS AND DETAILS.
4. THE LOCATION OF THE UTILITIES SHALL BE VERIFIED IN ADVANCE TO ALLOW FOR ALIGNMENT ADJUSTMENTS. CALL UTILITY LOCATES TWO (2) WORKING DAYS PRIOR TO CONSTRUCTION (1-800-553-4344).
5. A TAPPING COMPANY APPROVED BY CLARK PUBLIC UTILITIES SHALL BE USED TO MAKE ALL TAPS.
6. METER BOX ASSEMBLIES SHALL BE ARMORCAST, RAVEN, DFW OR APPROVED EQUAL.
7. NO CONNECTIONS WILL BE ALLOWED TO AN EXISTING SERVICE PRIOR TO AN APPROVED BACTERIOLOGICAL TEST. BACTERIOLOGICAL TEST SHALL PRECEDE PRESSURE TEST.
8. STUB SERVICES SHALL BE PRESSURE TESTED WITH THE MAIN LINE AND BE CAPABLE OF WITH-STANDING THE MAINS TEST PRESSURE.
9. WATER METER BOX SHALL BE PLACED IN NON-PAVED AREAS, OUT OF CONFLICT WITH DRIVEWAYS, LANDSCAPING AND OTHER UTILITIES. ALL METER BOXES PLACED IN CONFLICT AREAS SHALL BE MOVED AT CONTRACTORS EXPENSE.
10. ALL COMPRESSION FITTINGS TO HAVE STAINLESS STEEL INSERTS.

SERVICE SADDLES:

PROVIDE BRASS OR BRONZE SERVICE SADDLES WITH NEOPRENE GASKETS CEMENTED IN PLACE AND I.P.S. TAP AS SPECIFIED ON THE CONTRACT DRAWINGS. C900 PVC PIPE SHALL HAVE SERVICE SADDLES WITH BRASS BANDS; OTHERWISE, SADDLES SHALL BE SPECIFICALLY DESIGNED FOR THE TYPE OF PIPE TO WHICH THEY ARE BEING INSTALLED. SADDLES SHALL BE A MINIMUM OF 2' FROM A BELL AND 18" FROM A SADDLE.

1. SADDLES FOR 1" AND 2" SERVICE LINES ON WATER MAINS 8" AND SMALLER SHALL BE "ROMAC 101B" OR APPROVED EQUAL.
2. SADDLES FOR 1" AND 2" SERVICE LINES ON WATER MAINS 10" AND LARGER SHALL BE "ROMAC 202B" OR APPROVED EQUAL.

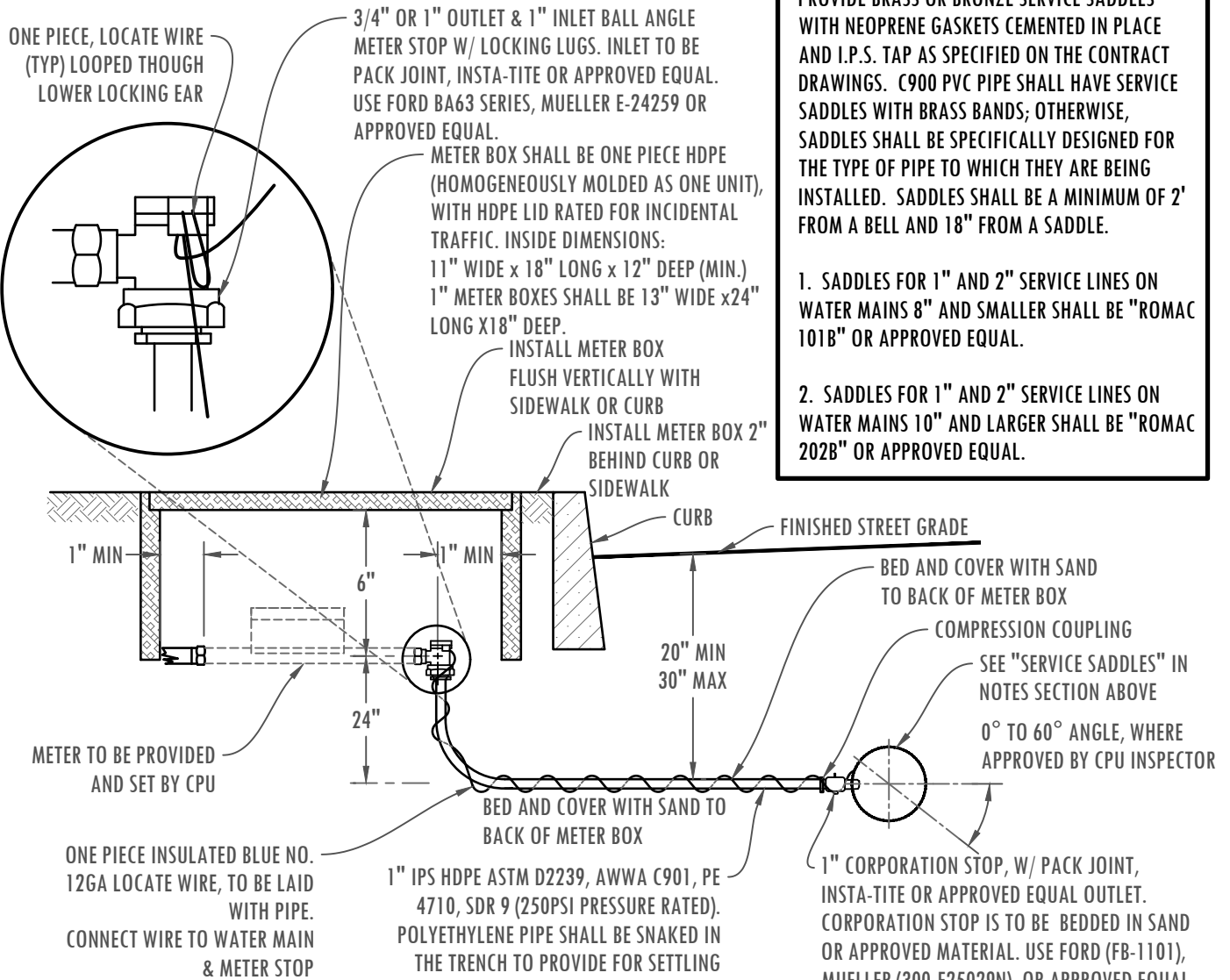

REVISED JANUARY 2025

FILE NAME		STANDARD 1" WATER SERVICE WITH 5/8", 3/4" OR 1" WATER METER	
1W			
SHEET	1 OF 1	STANDARD DETAILS	

NOTES:

1. ALL CONSTRUCTION MATERIALS AND WORKMANSHIP SHALL CONFORM TO THE CLARK PUBLIC UTILITIES (CPU) WATER CONSTRUCTION SPECIFICATIONS, STANDARD DETAILS AND THE LATEST EDITION OF THE "STANDARD SPECIFICATIONS FOR ROAD AND BRIDGE CONSTRUCTION" PUBLISHED BY WASHINGTON STATE DEPARTMENT OF TRANSPORTATION (WSDOT).
2. A WATER UTILITY INSPECTOR SHALL BE AT THE JOB SITE DURING CONSTRUCTION OF ALL WATER FACILITIES. CONTACT 360-992-8022 TWO (2) WORKING DAYS PRIOR TO COMMENCING WORK.
3. WORK WITHIN COUNTY RIGHT-OF-WAY SHALL CONFORM WITH CLARK COUNTY PUBLIC WORKS UTILITY PERMIT REQUIREMENTS AND DETAILS. WORK WITHIN STATE RIGHT-OF-WAY SHALL CONFORM TO WSDOT UTILITY PERMIT REQUIREMENTS AND DETAILS.
4. THE LOCATION OF THE UTILITIES SHALL BE VERIFIED IN ADVANCE TO ALLOW FOR ALIGNMENT ADJUSTMENTS. CALL UTILITY LOCATES TWO (2) WORKING DAYS PRIOR TO CONSTRUCTION (1-800-553-4344).
5. A TAPPING COMPANY APPROVED BY CLARK PUBLIC UTILITIES SHALL BE USED TO MAKE ALL TAPS.
6. NO CONNECTIONS WILL BE ALLOWED TO AN EXISTING SERVICE PRIOR TO AN APPROVED BACTERIOLOGICAL TEST. BACTERIOLOGICAL TEST SHALL PRECEDE PRESSURE TEST.
7. STUB SERVICES SHALL BE PRESSURE TESTED WITH THE MAIN LINE AND BE CAPABLE OF WITH-STANDING THE MAINS TEST PRESSURE.
8. ALL COMPRESSION FITTINGS TO HAVE STAINLESS STEEL INSERTS.

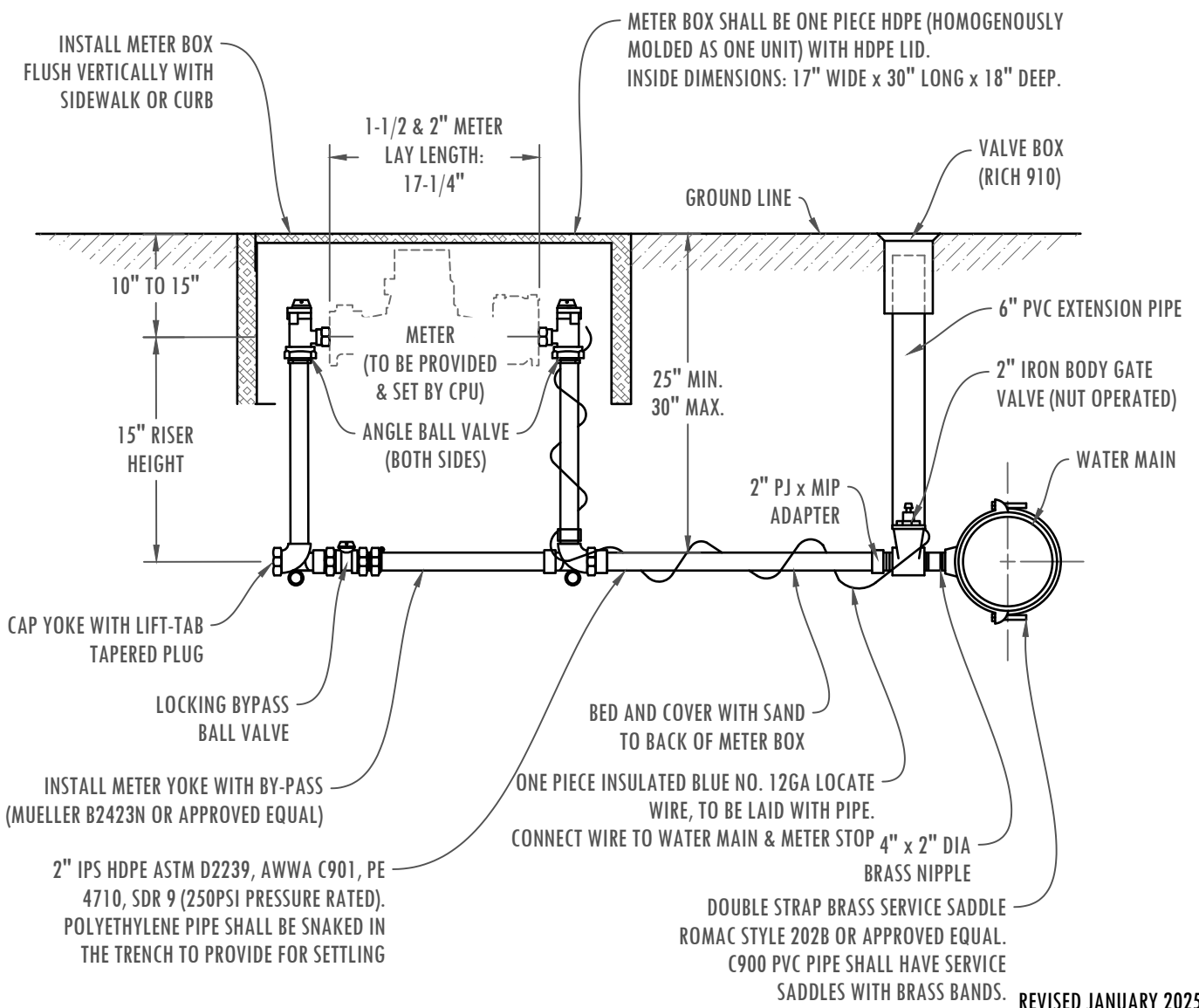

REVISED JANUARY 2025

FILE NAME		2" WATER SERVICE WITH 1-1/2" OR 2" WATER METER	
2W			
SHEET	1 OF 1	STANDARD DETAILS	

**ALL METERS SHALL BE INSTALLED
BY CLARK PUBLIC UTILITIES**

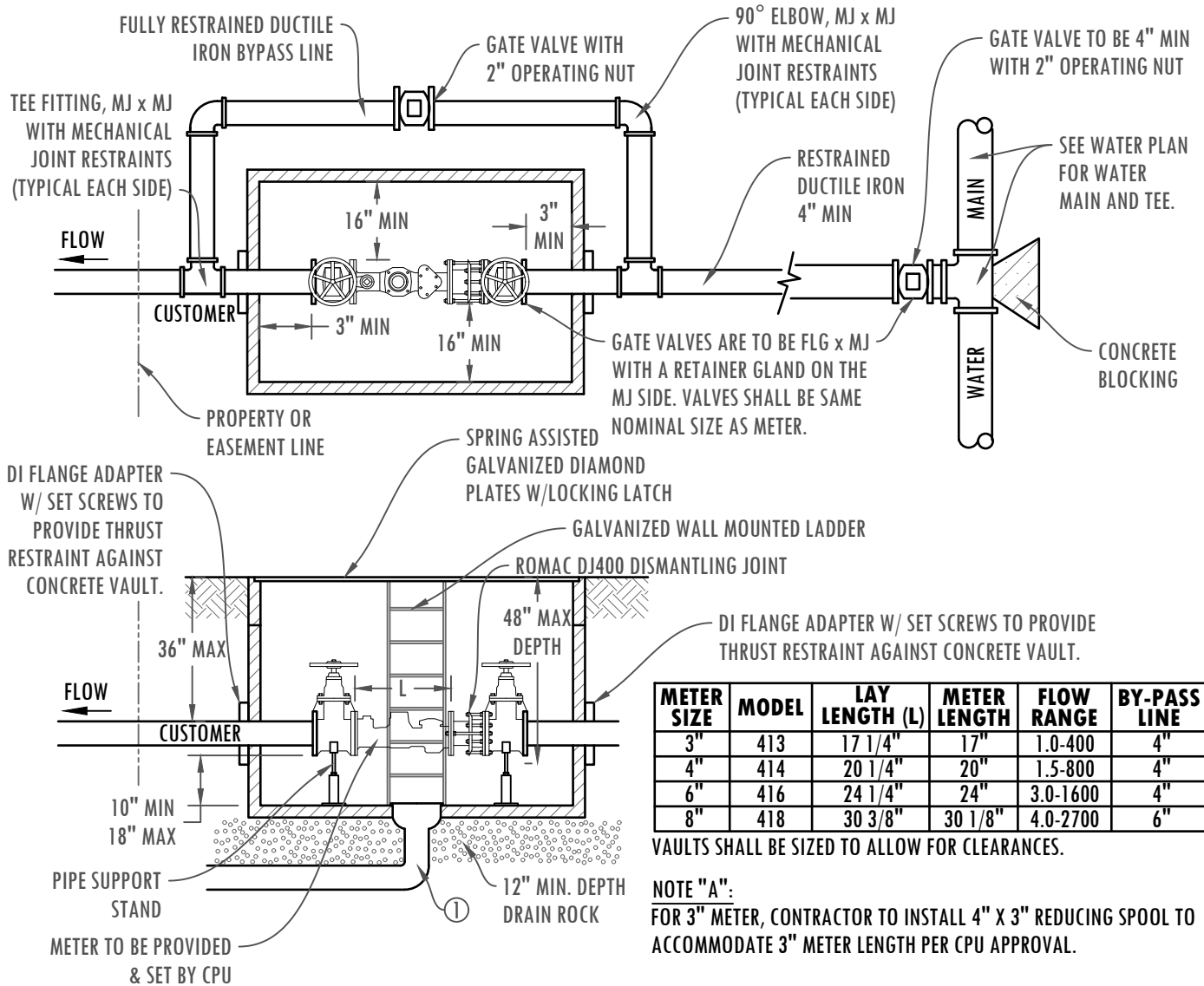

NOTE:

- ALL JOINTS SHALL BE RESTRAINED FROM THE MAIN LINE TEE TO THE BYPASS TEE DOWNSTREAM OF THE METER TO PROVIDE FOR METER REMOVAL. PIPE MATERIAL SHALL BE DUCTILE IRON.
- PRIOR TO METER INSTALLATION, GATE VALVES SHALL BE ALIGNED & SPACED W/ RIGID SPOOL (DRILLED WITH HOLES SO AS NOT TO ALLOW WATER PASSAGE). CONTACT CPU WATER UTILITY FOR DISTANCE BETWEEN METER GATE VALVES PRIOR TO INSTALLATION. (360-992-8022)
- TEN PIPE DIAMETERS OF STRAIGHT PIPE REQ'D. IN & OUT OF METER.
- INSTALL VAULT IN SOFT-SCAPE AREA, VERTICALLY FLUSH WITH CURB OR SIDEWALK.
- IF VAULT MUST BE LOCATED IN A WALKING AREA, A NON-SKID TRAFFIC RATED LID SHALL BE REQUIRED.

VAULT

VAULTS SHALL BE PRE-APPROVED PRIOR TO INSTALLATION
OLDCASTLE PRECAST VAULTS (OR APPROVED EQUAL):

- 3" & 4": #575-LA
- 6" & 8": #676-WA

- ① A 4-INCH DRAIN LINE SHALL BE EXTENDED TO AN APPROVED DRAINAGE OUTLET. IN LOCATIONS W/ NO FEASIBLE DRAINAGE SYSTEM, DRAIN MAY BE CONNECTED TO A CPU APPROVED DRYWELL SYSTEM.

REVISED JANUARY 2025

FILE NAME		3", 4", 6" AND 8" STANDARD METER INSTALLATION DETAILS	
3W			
SHEET	1 OF 1	STANDARD DETAILS	

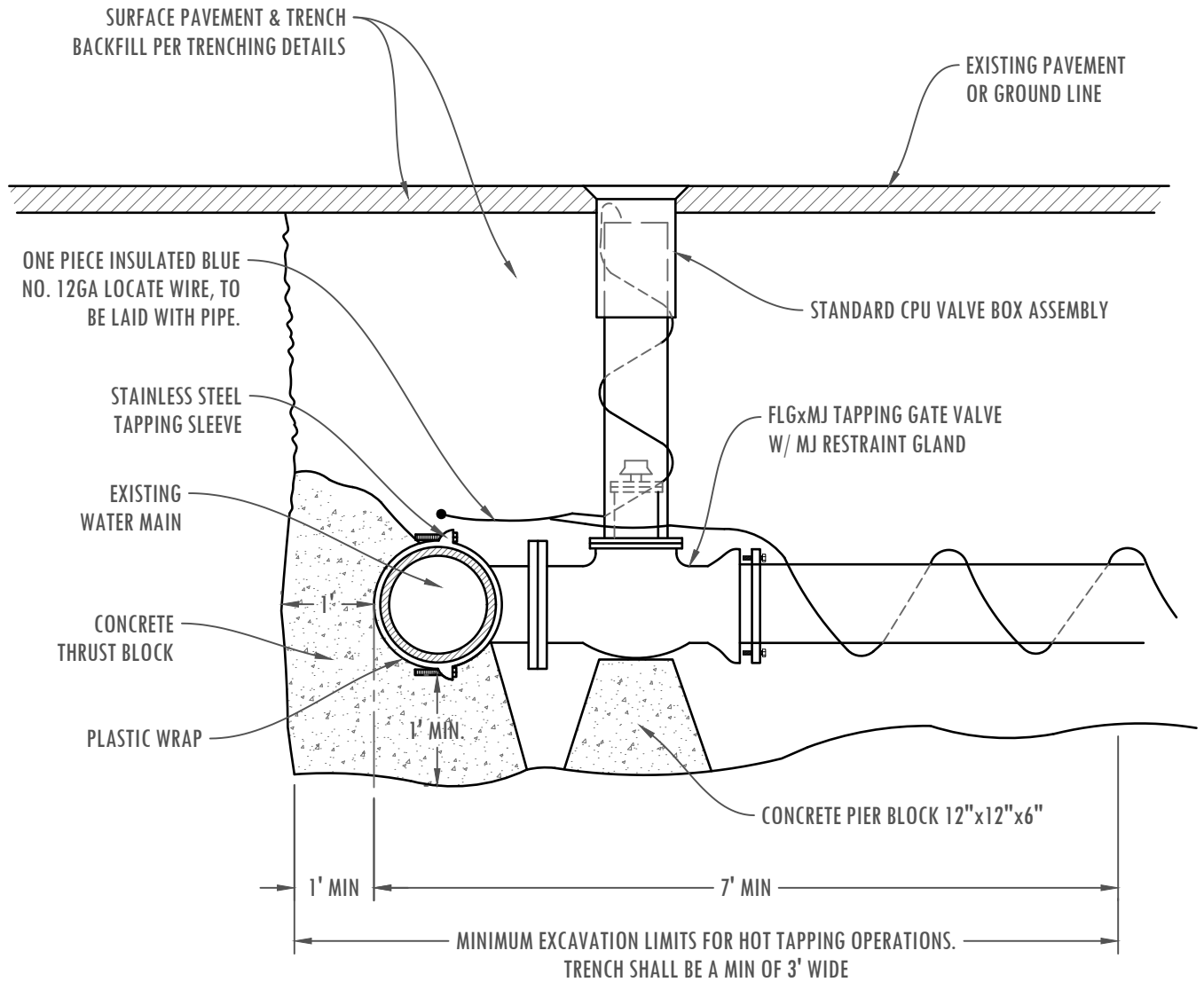

NOTES:

1. LAYOUT AND TAP LOCATION SHALL BE APPROVED BY THE CPU INSPECTOR PRIOR TO EXCAVATING. THE TAPPING COMPANY SHALL CONTACT THE CPU INSPECTOR TWO(2) WORKING DAYS IN ADVANCE PRIOR TO SCHEDULING THE HOT TAP.
2. HOT TAPS MAY ONLY BE DONE BY A CPU APPROVED TAPPING CONTRACTOR
3. THE CPU INSPECTOR SHALL BE AT THE WORKSITE DURING TAPPING OPERATIONS.
4. THRUST BLOCK SHALL BE POURED AGAINST FIRM UNDISTURBED SOIL. USE PLASTIC OR OTHER PROTECTIVE MATERIAL BETWEEN PIPE FITTINGS AND THRUST BLOCK.
5. TRENCH EXCAVATIONS OVER 4' WILL REQUIRE SHORING OR OTHER MEASURES CONSISTENT WITH APPLICABLE LOCAL, STATE OR FEDERAL SAFETY CODES.
6. ALLOW MINIMUM 24 HOURS FOR CONCRETE THRUST BLOCK TO CURE PRIOR TO CONNECTING TO PIPING.

REVISED JANUARY 2025

FILE NAME		STANDARD HOT TAP	
4W			
SHEET	1 OF 1	STANDARD DETAILS	

THRUST BLOCK NOTES:

1. CAST IN PLACE BLOCKING SHALL BE POURED WITHOUT DIRECT CONTACT TO THE PIPE OR FITTINGS.
2. PROTECTIVE MATERIAL SUCH AS PLASTIC OR APPROVED EQUAL SHALL BE PLACED BETWEEN THE CONCRETE AND PIPE OR FITTING.
3. BLOCKING SHALL BE DESIGNED FOR STATIC PRESSURE OF 200 PSI OR 1.5 TIMES THE WORKING PRESSURE, WHICHEVER IS GREATER.
4. CAST IN PLACE BLOCKING SHALL BE POURED AGAINST FIRM UNDISTURBED SOIL WITH MINIMUM BEARING PRESSURE OF 2,000 LB/SQ.FT.
5. CONCRETE FOR ALL BLOCKING SHALL HAVE A 28-DAY MINIMUM COMPRESSIVE STRENGTH OF 2,500 PSI.
6. CONCRETE BLOCKING FOR VERTICAL BENDS SHALL REQUIRE SITE SPECIFIC ENGINEERING DESIGN.
7. LAYOUT TO BE APPROVED BY THE INSPECTOR PRIOR TO AND AFTER CONCRETE PLACEMENT.
8. ALL THRUST BLOCKS SHALL BE PLACED IN CENTER OF TEE OR BEND.
9. THESE DETAILS IN NO WAY LIMIT THE SIZE OR LOCATION OF ADDITIONAL BLOCKING WHEN REQUESTED BY THE UTILITY.
10. THRUST BLOCKS ON WATER MAINS AND FITTINGS 12" OR LARGER SHALL BE DESIGNED BY A PROFESSIONAL ENGINEER AND APPROVED BY CLARK PUBLIC UTILITIES PRIOR TO CONSTRUCTION.

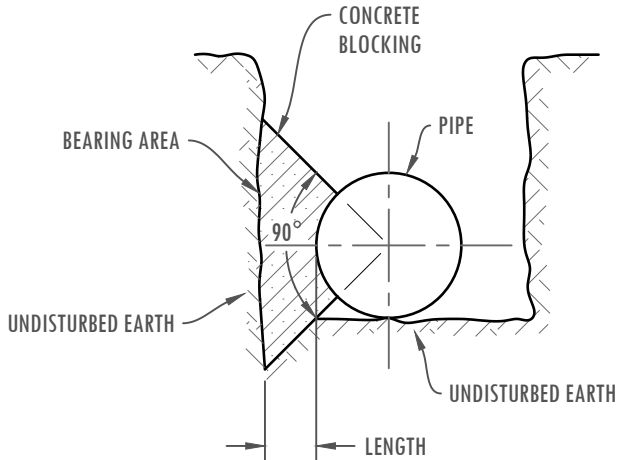

PIPE SIZE	HORIZ. FITTINGS (BENDS)	BEARING AREA (SF)	MINIMUM BLOCK SIZE (FT.)	MINIMUM LENGTH OF BLOCKING (FT.-IN.)
4"	TEE	1.9	1.5' x 1.5'	0'-6"
	90°	2.7	2.0' x 2.0'	0'-6"
	45°	1.4	1.5' x 1.5'	0'-6"
	22-1/2°	0.7	1.5' x 1.5'	0'-6"
6"	TEE	2.8	2.0' x 2.0'	0'-6"
	90°	4.0	2.0' x 2.0'	0'-6"
	45°	2.2	1.5' x 1.5'	0'-6"
	22-1/2°	1.1	1.5' x 1.5'	0'-6"
8"	TEE	5.0	2.0' x 3.0'	0'-8"
	90°	7.1	3.0' x 4.0'	0'-8"
	45°	3.8	2.0' x 2.0'	0'-6"
	22-1/2°	2.0	1.5' x 1.5'	0'-6"
10"	TEE	7.9	3.0' x 4.0'	0'-8"
	90°	11.1	3.0' x 4.0'	0'-8"
	45°	6.0	3.0' x 4.0'	0'-8"
	22-1/2°	3.1	2.0' x 2.0'	0'-6"
12"	TEE	11.3	3.0' x 4.0'	0'-8"
	90°	16.0	4.0' x 4.0'	1'-0"
	45°	8.7	3.0' x 4.0'	0'-8"
	22-1/2°	4.4	2.0' x 3.0'	0'-8"
	11-1/4°	3.3	2.0' x 2.0'	0'-6"

TABLE ASSUMES SOIL BEARING OF 2,000 LB/SQ.FT AND DESIGN WORKING PRESSURE OF 200 PSI

REVISED JANUARY 2025

FILE NAME		THRUST BLOCK	
5W			
SHEET	1 OF 1	STANDARD DETAILS	

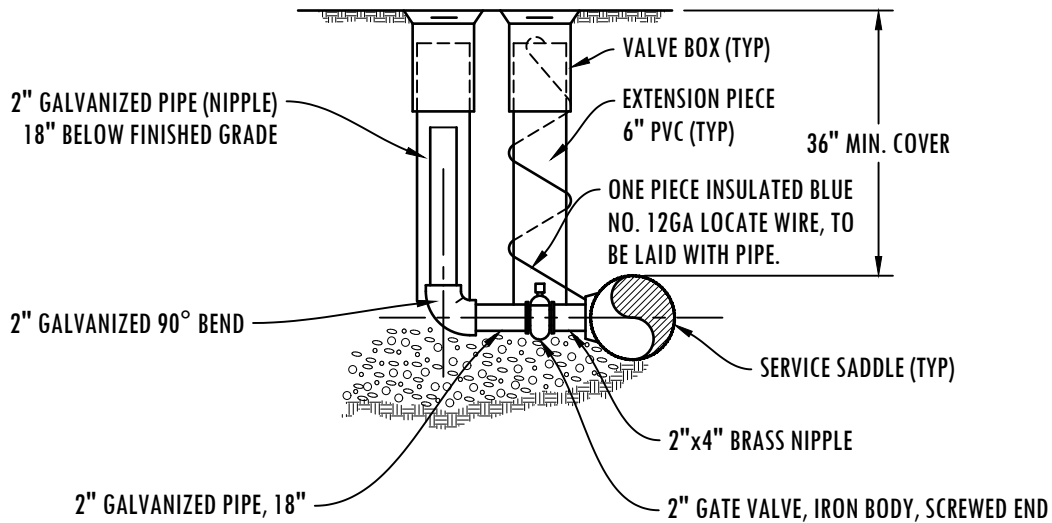
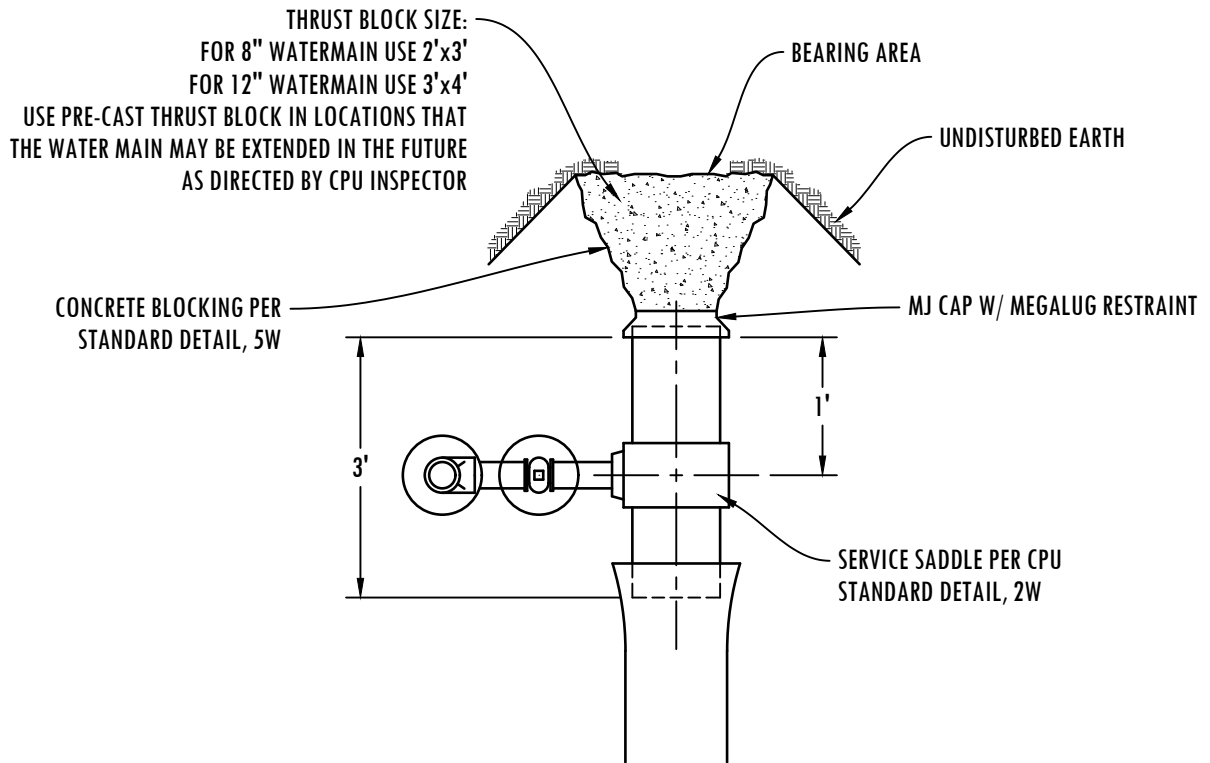

RESTRAINED PIPE LENGTHS					
PIPE TYPE	4"	6"	8"	10"	12"
PVC	40	56	74	90	107
DUCTILE IRON	29'	41'	55'	66'	70'

REVISED JANUARY 2025

FILE NAME		STANDARD END BLOW-OFF ASSEMBLY	
6W			
SHEET	1 OF 1	STANDARD DETAILS	

NOTES:

1. ALL CONSTRUCTION MATERIALS AND WORKMANSHIP SHALL CONFORM TO THE CLARK PUBLIC UTILITIES (CPU) WATER CONSTRUCTION SPECIFICATIONS, STANDARD DETAILS AND THE LATEST EDITION OF THE "STANDARD SPECIFICATIONS FOR ROAD AND BRIDGE CONSTRUCTION" PUBLISHED BY WASHINGTON STATE DEPARTMENT OF TRANSPORTATION (WSDOT).
2. A CPU WATER UTILITY INSPECTOR SHALL BE AT THE JOB SITE DURING CONSTRUCTION OF ALL WATER FACILITIES. CONTACT 360-992-8022 TWO (2) WORKING DAYS PRIOR TO COMMENCING WORK.
3. WORK WITHIN COUNTY RIGHT-OF-WAY SHALL CONFORM WITH CLARK COUNTY PUBLIC WORKS UTILITY PERMIT REQUIREMENTS AND DETAILS. WORK WITHIN STATE RIGHT-OF-WAY SHALL CONFORM TO WSDOT UTILITY PERMIT REQUIREMENTS AND DETAILS.

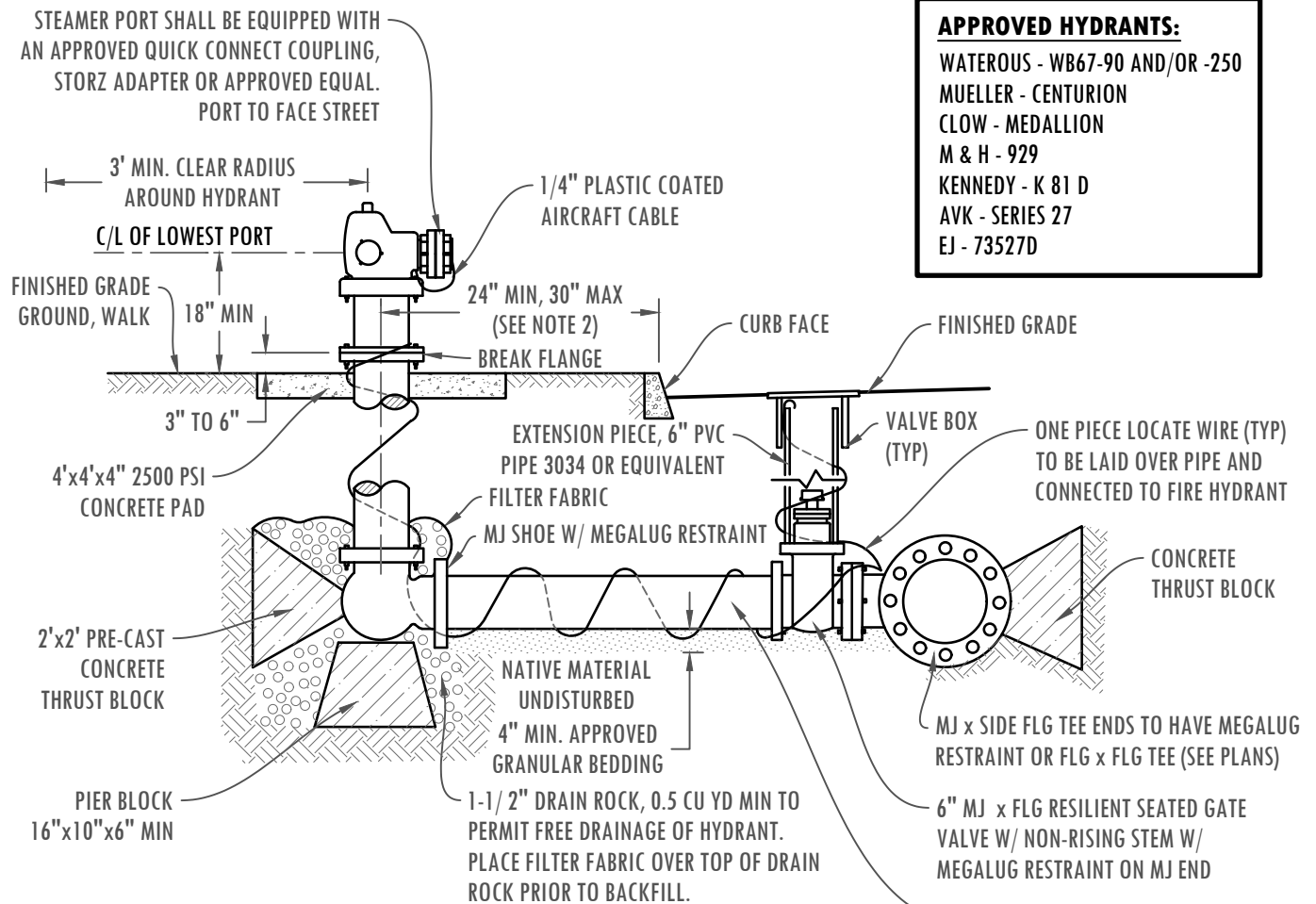

- APPROVED HYDRANTS:**
- WATEROUS - WB67-90 AND/OR -250
 - MUELLER - CENTURION
 - CLOW - MEDALLION
 - M & H - 929
 - KENNEDY - K 81 D
 - AVK - SERIES 27
 - EJ - 73527D

FIRE HYDRANT NOTES:

1. FIRE HYDRANT INSTALLATIONS SHALL BE INSPECTED PRIOR TO BACKFILLING.
2. WHERE HYDRANTS ARE SET BEHIND SIDEWALK, DISTANCE FROM BACK OF SIDEWALK TO HYDRANT C/L SHALL BE 18" MIN., 24" MAX.
3. FIRE HYDRANTS SHALL BE SHOP PAINTED PRIOR TO INSTALLATION W/ STANDARD A.W.W.A, GLOSS B, YELLOW
4. NO DOMESTIC OR FIRE PROTECTION SERVICE SHALL BE TAPPED OFF OF THE FIRE HYDRANT PIPING.
5. FIRE HYDRANT MAINS SHALL BE 8" MIN. A 6" MAIN CAN BE USED FOR A DEAD-END RUN OF LESS THAN 50' TO A FIRE HYDRANT SUBJECT TO ADEQUATE FIRE FLOW.
6. THE LOCATION OF THE UTILITIES SHALL BE VERIFIED IN ADVANCE TO ALLOW FOR ALIGNMENT ADJUSTMENTS. CALL UTILITY LOCATES TWO (2) WORKING DAYS PRIOR TO CONSTRUCTION (1-800-553-4344).
7. LOCATE WIRE SHALL BE INSULATED BLUE, NO. 12 GA. SOFT DRAWN SOLID COPPER.

REVISED JANUARY 2025

FILE NAME		STANDARD FIRE HYDRANT ASSEMBLY	
7W			
SHEET	1 OF 1	STANDARD DETAILS	

NOTES:

1. ALL CONSTRUCTION MATERIALS AND WORKMANSHIP SHALL CONFORM TO THE CLARK PUBLIC UTILITIES (CPU) WATER CONSTRUCTION SPECIFICATIONS, STANDARD DETAILS AND THE LATEST EDITION OF THE "STANDARD SPECIFICATIONS FOR ROAD AND BRIDGE CONSTRUCTION" PUBLISHED BY WASHINGTON STATE DEPARTMENT OF TRANSPORTATION (WSDOT).
2. IF THE OPERATING NUT HAS A DEPTH OF 5.0' OR MORE, A VALVE EXTENSION SHALL BE INSTALLED. OPERATING NUT SHALL NOT EXTEND INTO THE ROADWAY BASE ROCK.

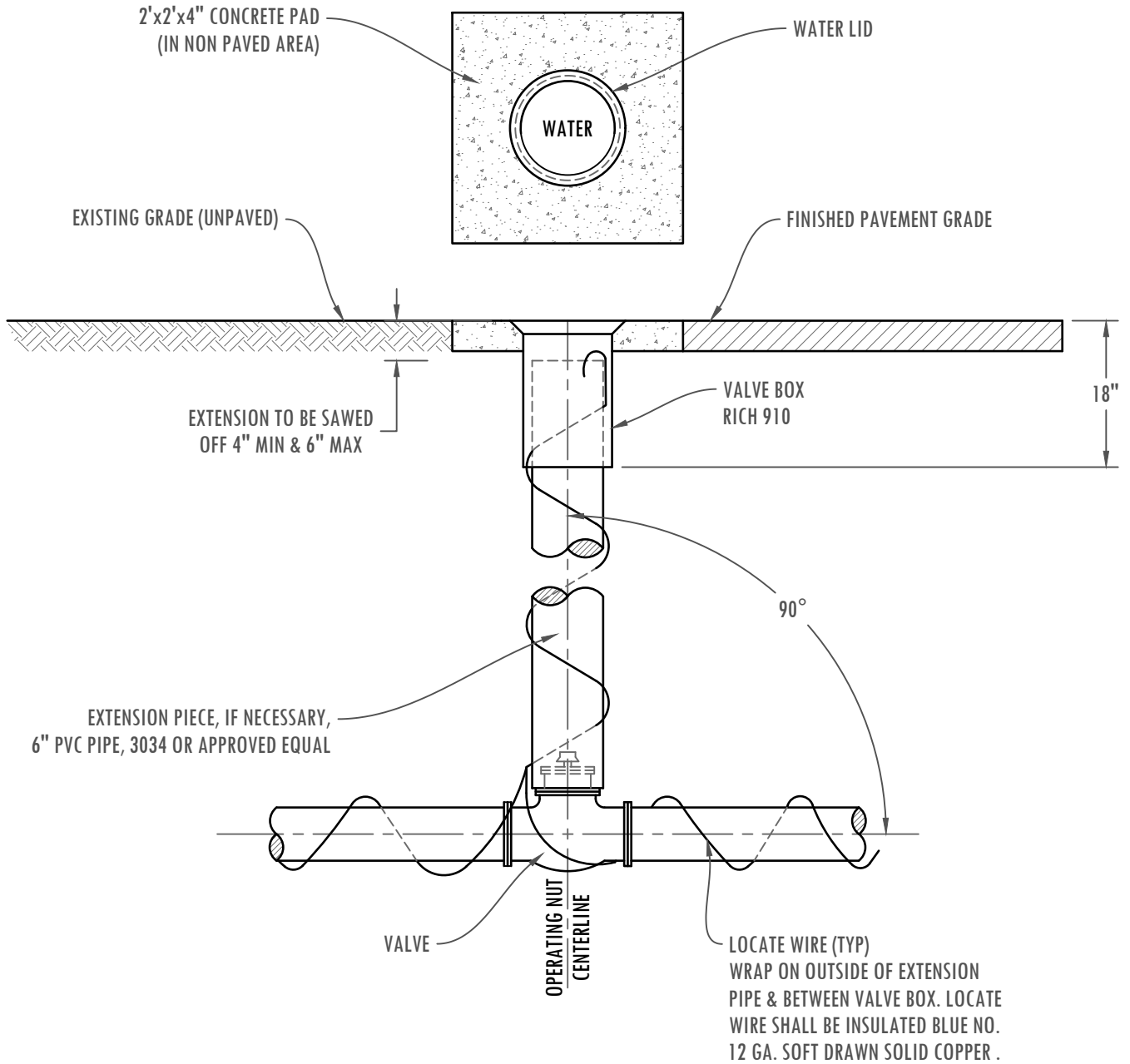

REVISED JANUARY 2025

FILE NAME		STANDARD VALVE BOX ASSEMBLY	
8W			
SHEET	1 OF 1	STANDARD DETAILS	

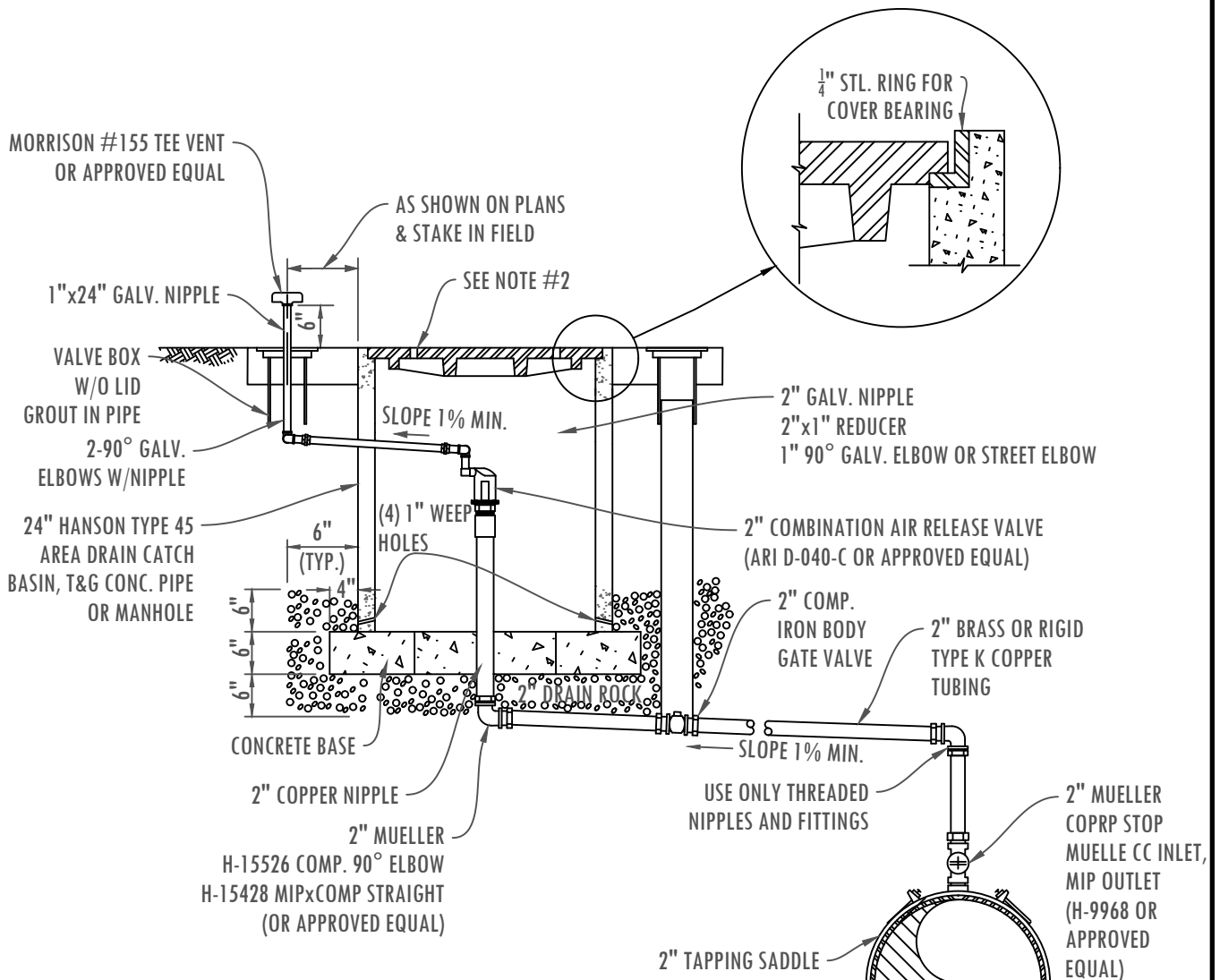

NOTES:

1. PLACE VENT AND AIR RELEASE UNIT ASSEMBLY OUTSIDE OF HARD SURFACED AREA IN R.O.W. OR 15' EASEMENT DEDICATED TO THE CITY OF VANCOUVER
2. MANHOLE COVER SHALL MEET SANITARY SEWER STANDARD DETAIL S-2.2 STANDARD LID OR APPROVED EQUAL.
3. ADD 4'x4'x4" CONCRETE PAD IF THE AIR RELEASE IS INSTALLED IN A "SOFTSCAPE" AREA.

REVISED JANUARY 2025

FILE NAME		COMBINATION AIR RELEASE VALVE	
9W			
SHEET	1 OF 1	STANDARD DETAILS	

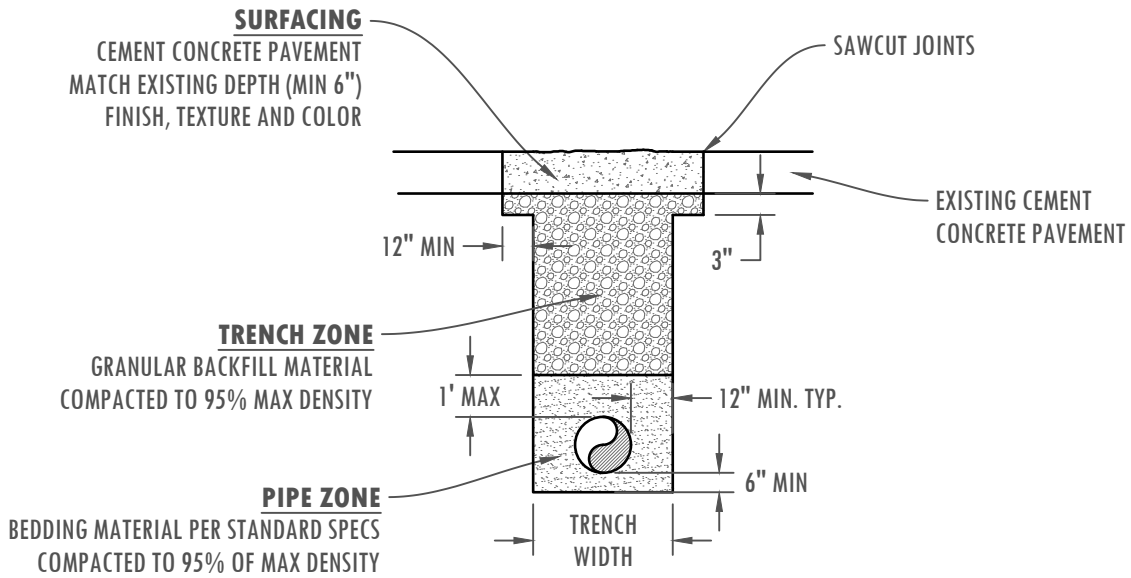

TRENCHING NOTES:

1. SEE CLARK COUNTY OR WSDOT UTILITY PERMIT, WHICHEVER IS APPLICABLE, FOR ADDITIONAL TRENCH BACKFILL AND SURFACING REQUIREMENTS.
2. NATIVE MATERIALS MAY BE SUBSTITUTED FOR IMPORTED GRANULAR MATERIAL PROVIDING IT IS PRE-APPROVED BY THE COUNTY ENGINEER OR AUTHORIZED REPRESENTATIVE.
3. TRENCH EXCAVATION, BEDDING, AND BACKFILL FOR WATER MAINS SHALL BE IN ACCORDANCE WITH SECTION 7-09 OF THE MOST CURRENT STANDARD SPECIFICATIONS. BED PIPE PER SUBSECTION 7-09.3(9) OF THE STANDARD SPECIFICATIONS.
4. IN THE TRENCH ZONE, USE METHOD C COMPACTION PER SECTION 2-03.3(14).
5. PIPE BEDDING (5/8"-0; AGG. BASE) SHALL BE A MINIMUM OF 12" EACH SIDE PIPE COMPACTED.

REVISED JANUARY 2025

FILE NAME		CEMENT CONCRETE PAVEMENT TYPE 'E' RESTORATION	Clark Public Utilities 
10W			
SHEET	1 OF 1	STANDARD DETAILS	

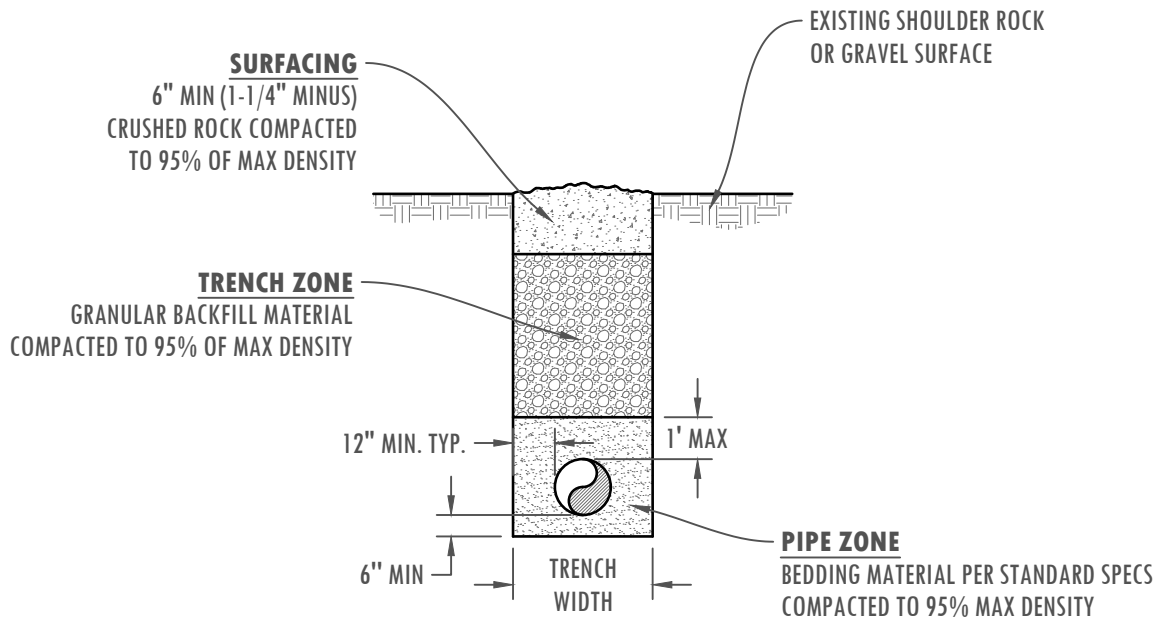

TRENCHING NOTES:

1. SEE CLARK COUNTY OR WSDOT UTILITY PERMIT, WHICHEVER IS APPLICABLE, FOR ADDITIONAL TRENCH BACKFILL AND SURFACING REQUIREMENTS.
2. NATIVE MATERIALS MAY BE SUBSTITUTED FOR IMPORTED GRANULAR MATERIAL PROVIDING IT IS PRE-APPROVED BY THE COUNTY ENGINEER OR AUTHORIZED REPRESENTATIVE.
3. TRENCH EXCAVATION, BEDDING, AND BACKFILL FOR WATER MAINS SHALL BE IN ACCORDANCE WITH SECTION 7-09 OF THE MOST CURRENT STANDARD SPECIFICATIONS. BED PIPE PER SUBSECTION 7-09.3(9) OF THE STANDARD SPECIFICATIONS.
4. IN THE TRENCH ZONE, USE METHOD C COMPACTION PER SECTION 2-03.3(14).
5. PIPE BEDDING (5/8"-0; AGG. BASE) SHALL BE A MINIMUM OF 12" EACH SIDE OF PIPE COMPACTED.

REVISED JANUARY 2025

FILE NAME		ROADWAY SHOULDERS, GRAVEL SURFACE TYPE 'B' RESTORATION	
11W			
SHEET	1 OF 1	STANDARD DETAILS	

TYPE 'C' PAVEMENT SECTION

TYPE 'C-1'
 (COLLECTOR OR ARTERIAL)
 0.50' A.C.P. OVER
 0.80' OF 1-1/4" MINUS C.S.B.C.

TYPE 'C-2'
 (RESIDENTIAL)
 0.35' A.C.P. OVER
 0.20' OF 5/8" MINUS C.S.T.C. OVER
 0.80' 1-1/4" MINUS C.S.B.C.

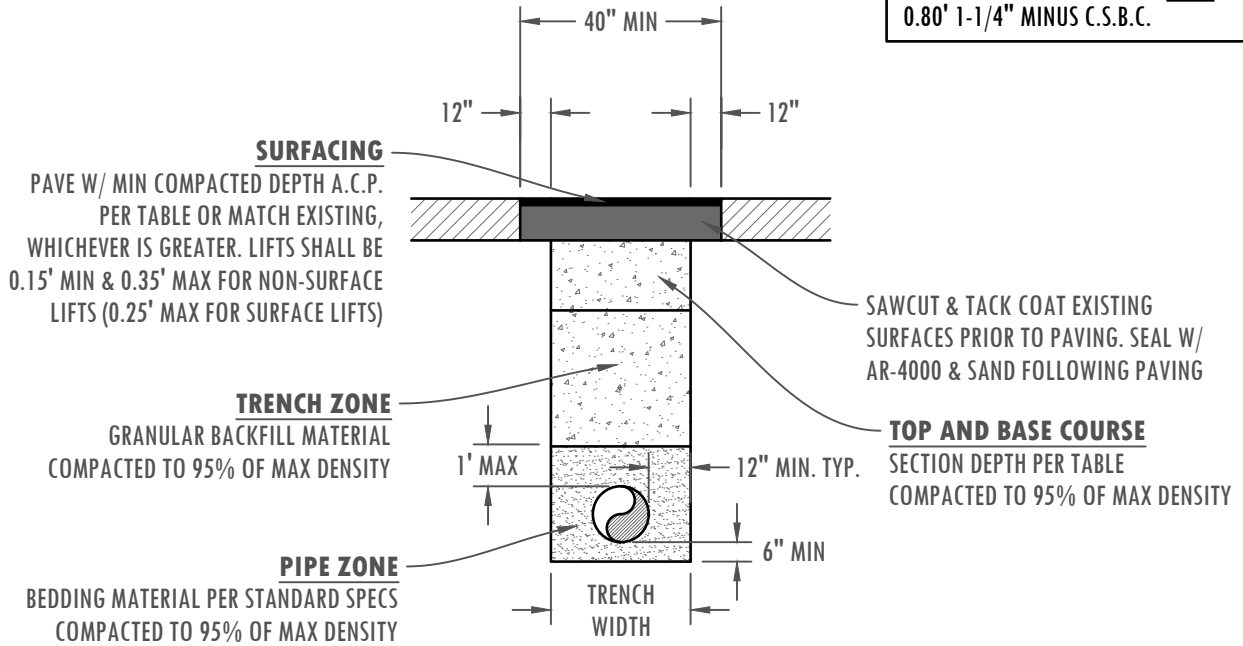

TRENCHING NOTES:

1. SEE CLARK COUNTY OR WSDOT UTILITY PERMIT, WHICHEVER IS APPLICABLE, FOR ADDITIONAL TRENCH BACKFILL AND SURFACING REQUIREMENTS.
2. NATIVE MATERIALS MAY BE SUBSTITUTED FOR IMPORTED GRANULAR MATERIAL PROVIDING IT IS PRE-APPROVED BY THE COUNTY ENGINEER OR AUTHORIZED REPRESENTATIVE.
3. TRENCH EXCAVATION, BEDDING, AND BACKFILL FOR WATER MAINS SHALL BE IN ACCORDANCE WITH SECTION 7-09 OF THE MOST CURRENT STANDARD SPECIFICATIONS. BED PIPE PER SUBSECTION 7-09.3(9) OF THE STANDARD SPECIFICATIONS.
4. IN THE TRENCH ZONE, USE METHOD C COMPACTION PER SECTION 2-03.3(14).
5. PIPE BEDDING (5/8"-0; AGG. BASE) SHALL BE A MINIMUM OF 12" EACH SIDE OF PIPE COMPACTED.

REVISED JANUARY 2025

FILE NAME		ASPHALT CONCRETE PAVEMENT TYPE 'C1' & 'C2' RESTORATION	
12W			
SHEET	1 OF 1	STANDARD DETAILS	

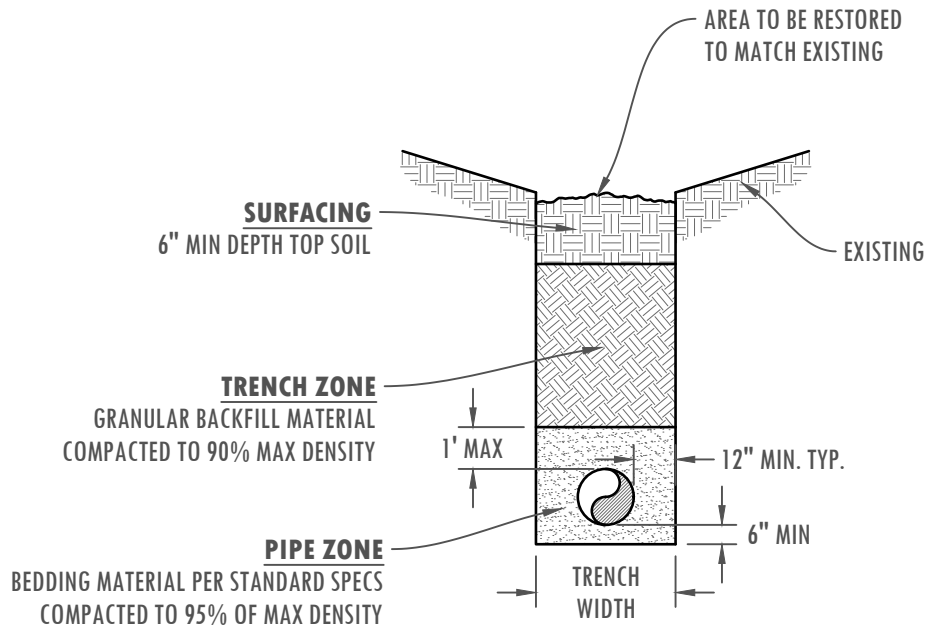

TRENCHING NOTES:

1. SEE CLARK COUNTY OR WSDOT UTILITY PERMIT, WHICHEVER IS APPLICABLE, FOR ADDITIONAL TRENCH BACKFILL AND SURFACING REQUIREMENTS.
2. NATIVE MATERIALS MAY BE SUBSTITUTED FOR IMPORTED GRANULAR MATERIAL PROVIDING IT IS PRE-APPROVED BY THE COUNTY ENGINEER OR AUTHORIZED REPRESENTATIVE.
3. TRENCH EXCAVATION, BEDDING, AND BACKFILL FOR WATER MAINS SHALL BE IN ACCORDANCE WITH SECTION 7-09 OF THE MOST CURRENT STANDARD SPECIFICATIONS. BED PIPE PER SUBSECTION 7-09.3(9) OF THE STANDARD SPECIFICATIONS.
4. IN THE TRENCH ZONE, USE METHOD C COMPACTION PER SECTION 2-03.3(14).
5. PIPE BEDDING (5/8"-0; AGG. BASE) SHALL BE A MINIMUM OF 12" EACH SIDE OF PIPE COMPACTED.

REVISED JANUARY 2025

FILE NAME		NATIVE BACKFILL OUTSIDE ROADWAY TYPE 'A' RESTORATION	
13W			
SHEET	1 OF 1	STANDARD DETAILS	

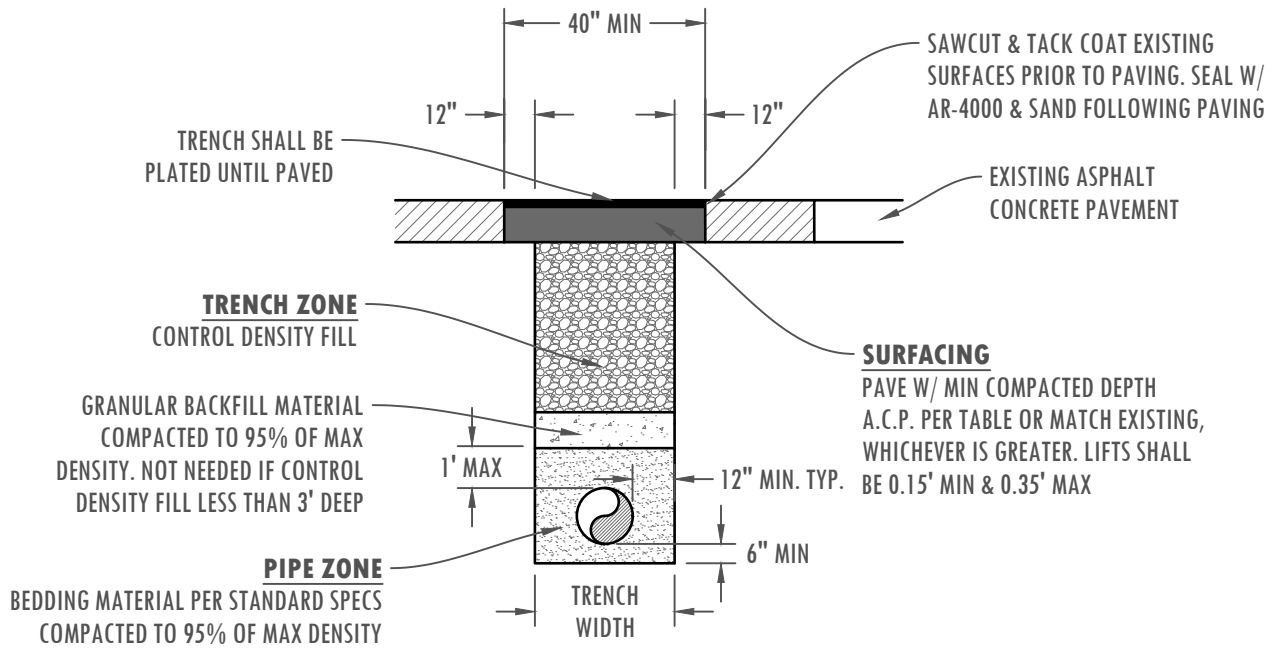

TRENCHING NOTES:

1. SEE CLARK COUNTY OR WSDOT UTILITY PERMIT, WHICHEVER IS APPLICABLE, FOR ADDITIONAL TRENCH BACKFILL AND SURFACING REQUIREMENTS.
2. NATIVE MATERIALS MAY BE SUBSTITUTED FOR IMPORTED GRANULAR MATERIAL PROVIDING IT IS PRE-APPROVED BY THE COUNTY ENGINEER OR AUTHORIZED REPRESENTATIVE.
3. TRENCH EXCAVATION, BEDDING, AND BACKFILL FOR WATER MAINS SHALL BE IN ACCORDANCE WITH SECTION 7-09 OF THE MOST CURRENT STANDARD SPECIFICATIONS. BED PIPE PER SUBSECTION 7-09.3(9) OF THE STANDARD SPECIFICATIONS.
4. IN THE TRENCH ZONE, USE METHOD C COMPACTION PER SECTION 2-03.3(14).
5. PIPE BEDDING (5/8"-0; AGG. BASE) SHALL BE A MINIMUM OF 12" EACH SIDE OF PIPE COMPACTED.

REVISED JANUARY 2025

FILE NAME		CONTROL DENSITY FILL - ASPHALT CONCRETE PAVEMENT TYPE 'D' RESTORATION	
14W			
SHEET	1 OF 1	STANDARD DETAILS	

TYPICAL BELOW GROUND INSTALLATION

A CLARK PUBLIC UTILITIES APPROVED VALVE AND WATER MAIN IS REQUIRED BETWEEN THE SUPPLY MAIN AND THE VAULT

DI FLANGE ADAPTER W/ SET SCREW TO PROVIDE THRUST RESTRAINT AGAINST CONCRETE VAULT

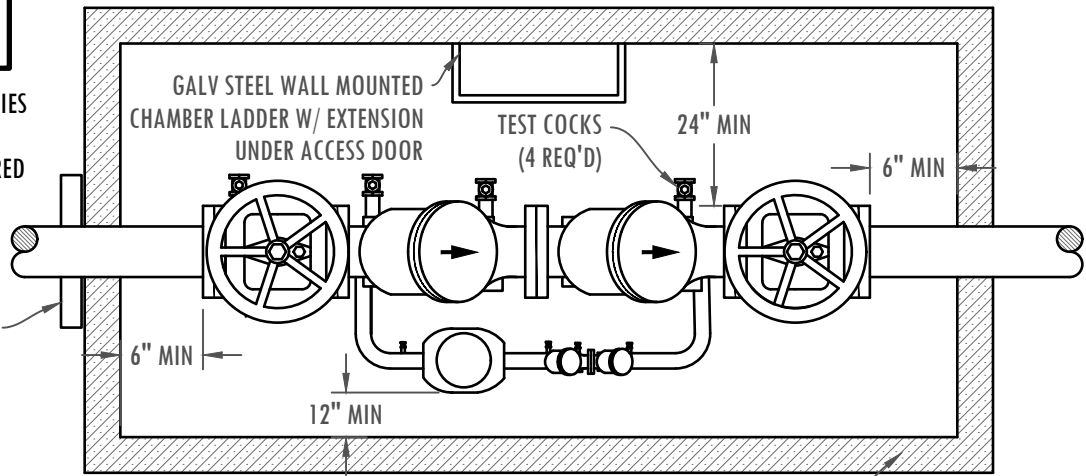

TOP VIEW

VAULT SHALL BE EQUIPPED W/ 36" x 36" SPRING ASSISTED, HOT DIPPED GALV DIAMOND PLATE DOOR. UTILITY VAULT #332P-MODEL 1980.

PRE-CAST CONCRETE VAULT H-20 LOADING W/ LADDER UTILITY VAULT #577-LA

3" MIN WHEN VALVE IS FULLY OPEN

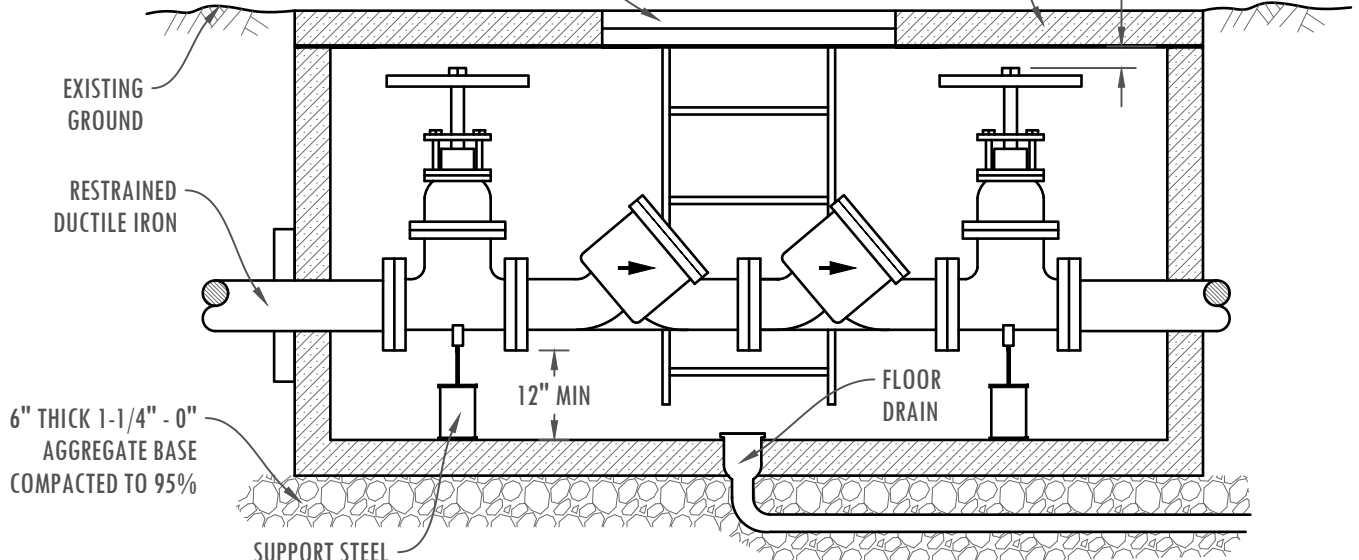

SIDE VIEW

NOTES:

1. APPROVED DOUBLE CHECK DETECTOR ASSEMBLY TO LAY HORIZONTAL WITH THE GROUND.
2. DESIGNED FOR BACK SIPHONAGE AND BACK PRESSURE.
3. THE WATER LINE SHALL BE DISINFECTED, FLUSHED, AND PRESSURE TESTED PRIOR TO INSTALLING THE BACKFLOW ASSEMBLY. THE BACKFLOW ASSEMBLY SHALL BE PROTECTED FROM FREEZING AND FLOODING IN AN INSULATED ENCLOSURE IF INSTALLED ABOVE GROUND.
4. THE D.C.D.A. MAY BE INSTALLED ABOVE OR BELOW GROUND PROVIDED ALL CLEARANCES ARE MET.
5. ALL PIPE, VALVE, AND FITTING JOINTS, FROM THE SUPPLY MAIN, SHALL BE RESTRAINED.
6. FIRE DEPT. CONNECTION SHALL NOT EXIT THROUGH THE TOP OF THE VAULT.
7. GROUT PIPE ENTRANCE AND EXIT, IN VAULT, WITH WATER-TITE GROUT.
8. ALL VAULTS SHALL BE PRE-APPROVED PRIOR TO INSTALLATION.
9. VAULTS SHALL BE INSTALLED AT PROPERTY LINE OR EASEMENT LINE AND ON OWNERS PROPERTY.
10. VAULTS SHALL HAVE A MINIMUM OF 3' CLEARANCE FROM ALL STRUCTURES.
11. THE BACKFLOW ASSEMBLY SHALL BE TESTED AFTER INSTALLATION AND PRIOR TO ACCEPTANCE AND ALSO YEARLY THEREAFTER BY A WASHINGTON STATE CERTIFIED BACKFLOW ASSEMBLY TESTER. TEST RESULTS SHALL BE SENT TO CLARK PUBLIC UTILITIES WATER SERVICES.

REVISED JANUARY 2025

FILE NAME		STANDARD DCDA (DOUBLE CHECK DETECTOR ASSEMBLY) 2-1/2" & LARGER	
15W			
SHEET	1 OF 1	STANDARD DETAILS	

**TYPICAL BELOW
GROUND
INSTALLATION**

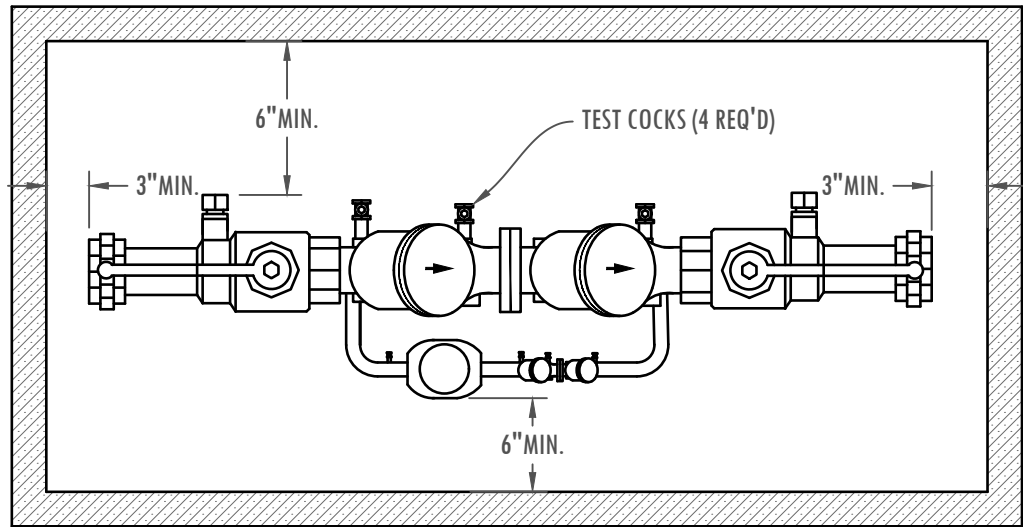

TOP VIEW

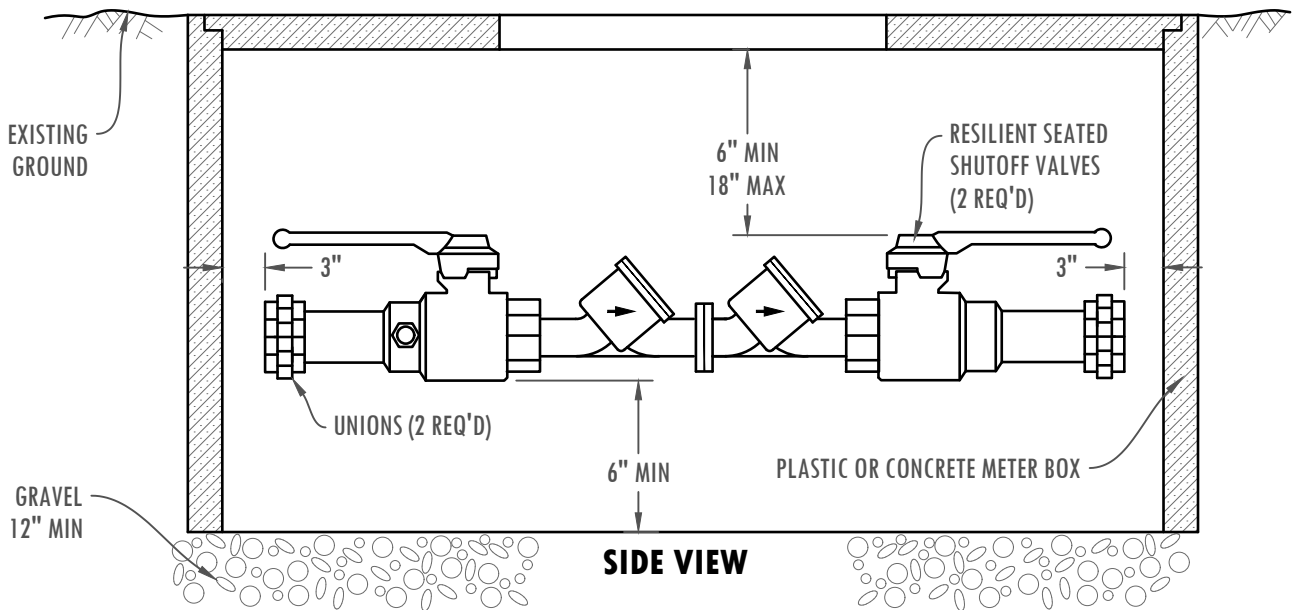

SIDE VIEW

NOTES:

1. APPROVED DOUBLE CHECK DETECTOR ASSEMBLY TO LAY HORIZONTAL WITH GROUND.
2. DESIGNED FOR BACK SIPHONAGE AND BACK PRESSURE.
3. TEST COCKS TO EITHER FACE OUTWARDS OR UPWARDS FROM ASSEMBLY.
4. DISINFECT, PRESSURE TEST AND THOROUGHLY FLUSH LINES PRIOR TO INSTALLATION OF BACKFLOW PREVENTER.
5. THE DCDA MAY BE INSTALLED ABOVE OR BELOW THE GROUND PROVIDED ALL CLEARANCES ARE MET
6. DO NOT INSTALL IN AN AREA SUBJECT TO FLOODING.
7. MUST BE PROTECTED FROM FREEZING CONDITIONS IN AN INSULATED ENCLOSURE IF INSTALLED ABOVE GROUND.
8. THE BACKFLOW ASSEMBLY SHALL BE A STATE APPROVED MODEL.
9. A PLUMBING PERMIT IS REQUIRED. PLEASE CONTACT YOUR LOCAL PLUMBING PERMIT CENTER.
10. MUST BE TESTED AFTER INSTALLATION AND YEARLY THEREAFTER BY A WASHINGTON STATE CERTIFIED BACKFLOW ASSEMBLY TESTER. TEST RESULTS SHALL BE SENT TO CLARK PUBLIC UTILITIES WATER SERVICES.

REVISED JANUARY 2025

FILE NAME		STANDARD DCDA (DOUBLE CHECK DETECTOR ASSEMBLY) 2" & SMALLER	
16W			
SHEET	1 OF 1	STANDARD DETAILS	

TYPICAL BELOW GROUND INSTALLATION

A CLARK PUBLIC UTILITIES APPROVED VALVE AND WATER MAIN IS REQUIRED BETWEEN THE SUPPLY MAIN AND THE VAULT

DI FLANGE ADAPTER W/ SET SCREW TO PROVIDE THRUST RESTRAINT AGAINST CONCRETE VAULT

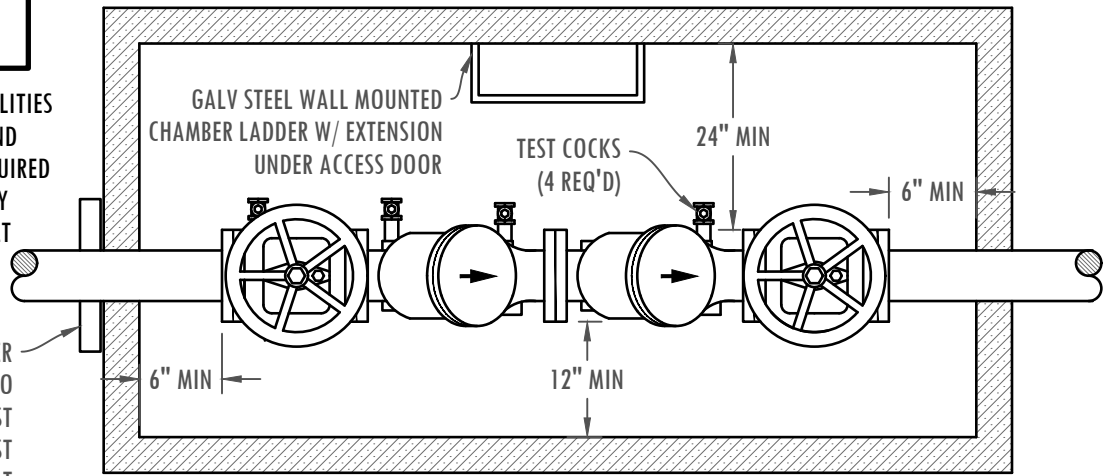

TOP VIEW

VAULT SHALL BE EQUIPPED W/ 36" x 36" SPRING ASSISTED, HOT DIPPED GALV DIAMOND PLATE DOOR. UTILITY VAULT #332P-MODEL 1980.

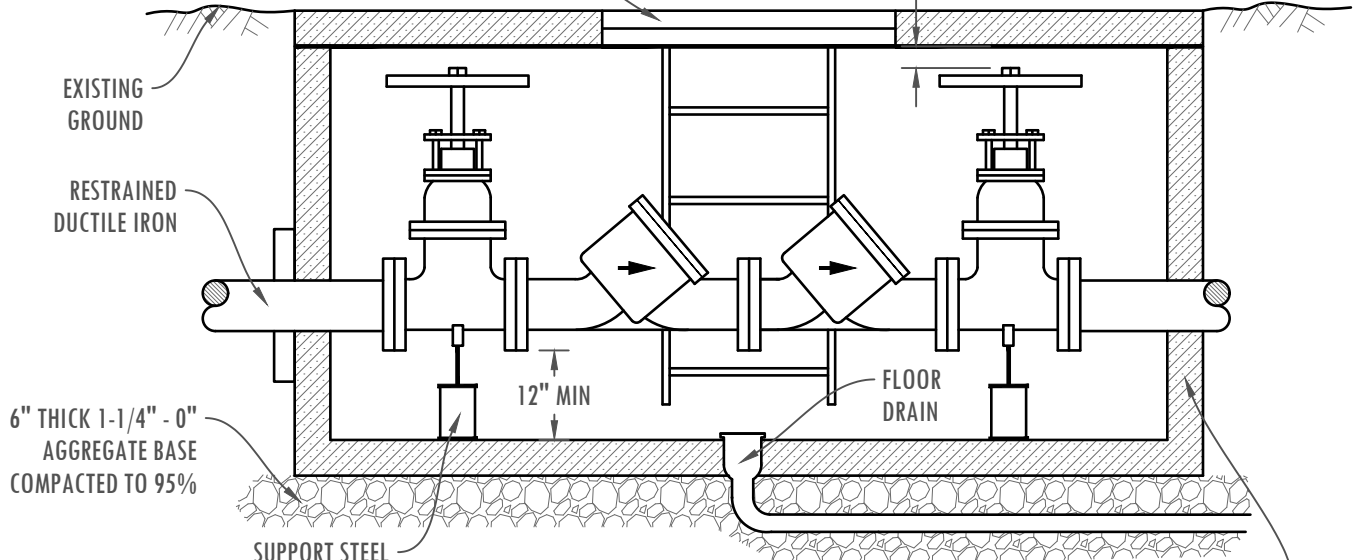

SIDE VIEW

NOTES:

1. APPROVED DOUBLE CHECK VALVE ASSEMBLY TO LAY HORIZONTAL WITH THE GROUND.
2. DESIGNED FOR BACK SIPHONAGE AND BACK PRESSURE.
3. THE WATER LINE SHALL BE DISINFECTED, FLUSHED, AND PRESSURE TESTED PRIOR TO INSTALLING THE BACKFLOW ASSEMBLY. THE BACKFLOW ASSEMBLY SHALL BE PROTECTED FROM FREEZING AND FLOODING IN AN INSULATED ENCLOSURE IF INSTALLED ABOVE GROUND.
4. THE D.C.V.A. MAY BE INSTALLED ABOVE OR BELOW GROUND PROVIDED ALL CLEARANCES ARE MET.
5. ALL PIPE, VALVE, AND FITTING JOINTS FROM THE SUPPLY MAIN SHALL BE RESTRAINED.
6. FIRE DEPT. CONNECTION SHALL NOT EXIT THROUGH THE TOP OF THE VAULT.
7. GROUT PIPE ENTRANCE AND EXIT, IN VAULT, WITH WATER-TITE GROUT.
8. ALL VAULTS SHALL BE PRE-APPROVED PRIOR TO INSTALLATION.
9. VAULTS SHALL BE INSTALLED AT PROPERTY LINE OR EASEMENT LINE AND ON OWNERS PROPERTY.
10. VAULTS SHALL HAVE A MINIMUM OF 3' CLEARANCE FROM ALL STRUCTURES.
11. THE BACKFLOW ASSEMBLY SHALL BE TESTED AFTER INSTALLATION AND PRIOR TO ACCEPTANCE AND ALSO YEARLY THEREAFTER BY A WASHINGTON STATE CERTIFIED BACKFLOW ASSEMBLY TESTER. TEST RESULTS SHALL BE SENT TO CLARK PUBLIC UTILITIES WATER SERVICES.

PRE-CAST CONCRETE VAULT H-20 LOADING W/ LADDER UTILITY VAULT #577-LA

REVISED JANUARY 2025

FILE NAME		STANDARD DCVA (DOUBLE CHECK VALVE ASSEMBLY) 2-1/2" & LARGER	
17W			
SHEET	1 OF 1	STANDARD DETAILS	

**TYPICAL BELOW
GROUND
INSTALLATION**

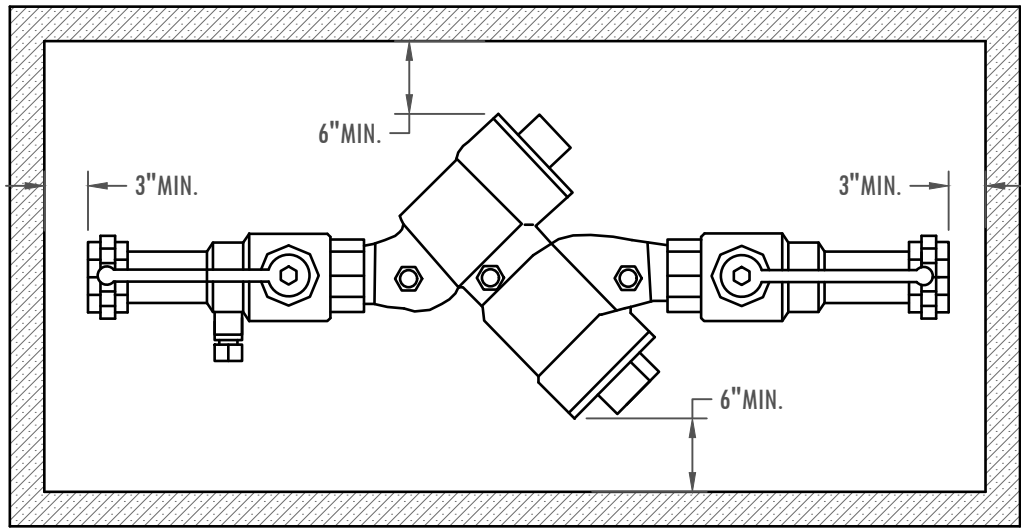

TOP VIEW

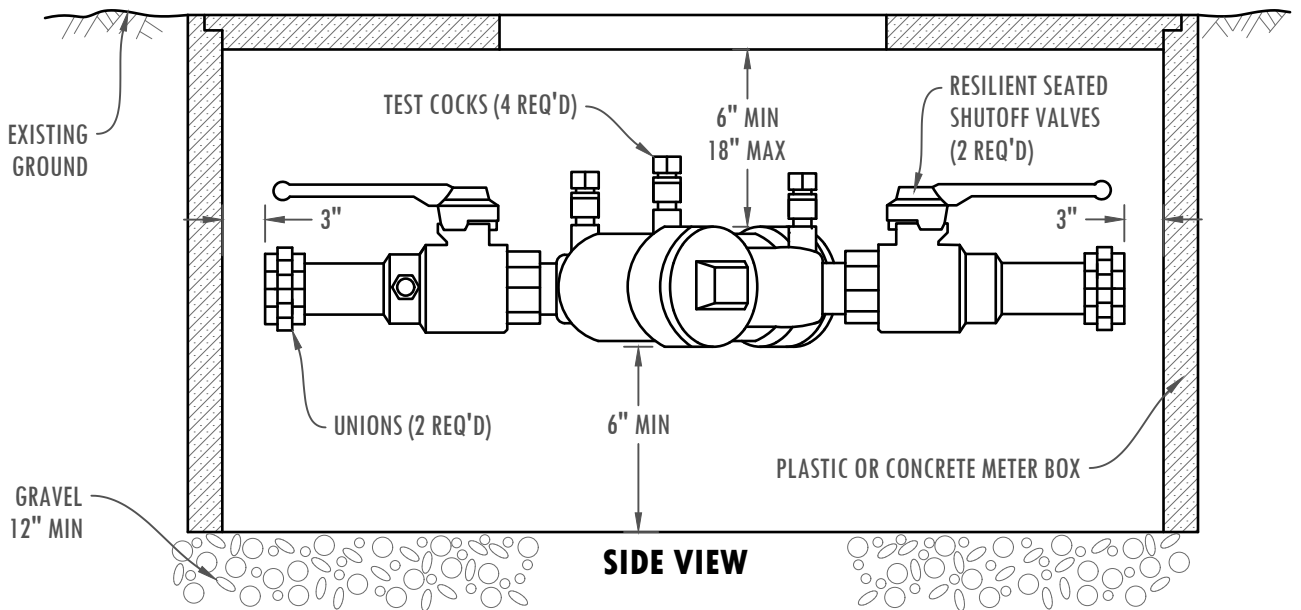

SIDE VIEW

NOTES:

1. APPROVED DOUBLE CHECK VALVE ASSEMBLY TO LAY HORIZONTAL WITH GROUND.
2. DESIGNED FOR BACK SIPHONAGE AND BACK PRESSURE.
3. TEST COCKS TO EITHER FACE OUTWARDS OR UPWARDS FROM ASSEMBLY.
4. DISINFECT, PRESSURE TEST AND THOROUGHLY FLUSH LINES PRIOR TO INSTALLATION OF BACKFLOW PREVENTER.
5. THE DCVA MAY BE INSTALLED ABOVE OR BELOW THE GROUND PROVIDED ALL CLEARANCES ARE MET
6. DO NOT INSTALL IN AN AREA SUBJECT TO FLOODING.
7. MUST BE PROTECTED FROM FREEZING CONDITIONS.
8. THE BACKFLOW ASSEMBLY SHALL BE A STATE APPROVED MODEL.
9. A PLUMBING PERMIT IS REQUIRED. PLEASE CONTACT YOUR LOCAL PLUMBING PERMIT CENTER.
10. MUST BE TESTED AFTER INSTALLATION AND YEARLY THEREAFTER BY A WASHINGTON STATE CERTIFIED BACKFLOW ASSEMBLY TESTER. TEST RESULTS SHALL BE SENT TO CLARK PUBLIC UTILITIES WATER SERVICES.

REVISED JANUARY 2025

FILE NAME		STANDARD DCVA (DOUBLE CHECK VALVE ASSEMBLY) 2" & SMALLER	Clark Public Utilities 
18W			
SHEET	1 OF 1	STANDARD DETAILS	

**ABOVE GROUND
INSTALLATION**

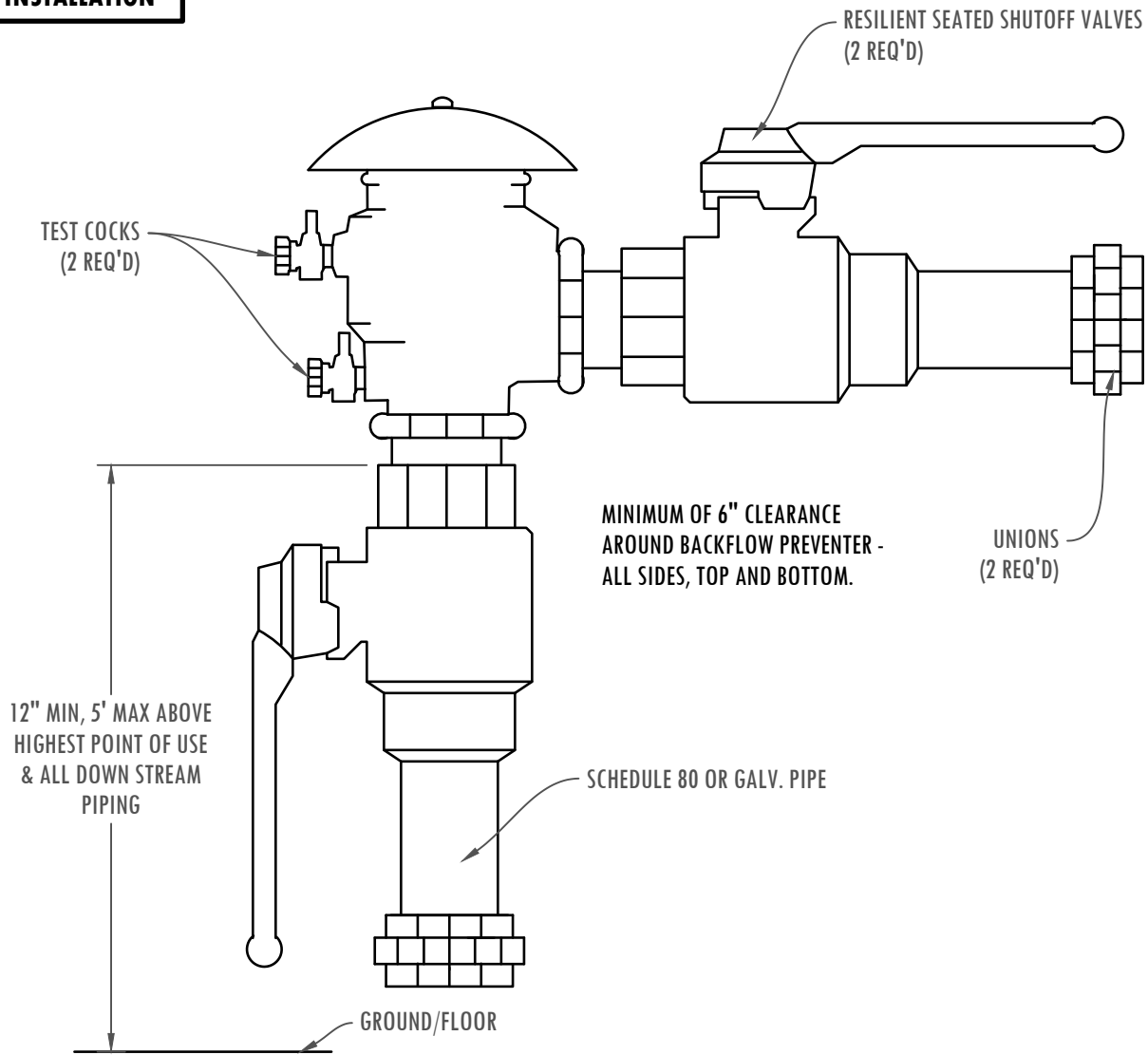

1. APPROVED PRESSURE VALVE BREAKER ASSEMBLY MUST BE INSTALLED VERTICALLY, 12" MIN TO 5' MAX ABOVE THE HIGHEST POINT OF USE AND ALL DOWNSTREAM PIPING.
2. DESIGNED FOR BACK SIPHONAGE ONLY, NOT BACK PRESSURE.
3. DISINFECT, PRESSURE TEST AND THOROUGHLY FLUSH LINES PRIOR TO INSTALLATION OF BACKFLOW PREVENTER.
4. IF A PVBA IS INSTALLED INDOORS, CONSIDERATION MUST BE GIVEN TO WATER LEAKAGE IF THE BACKFLOW PREVENTER FAILS (EXCESSIVE WATER SPILLAGE).
5. THE BACKFLOW ASSEMBLY SHALL BE PROTECTED FROM FREEZING AND FLOODING.
6. THE BACKFLOW ASSEMBLY SHALL BE A STATE APPROVED MODEL.
7. A PLUMBING PERMIT IS REQ'D. PLEASE CONTACT YOUR LOCAL PLUMBING PERMIT CENTER.
8. MUST BE TESTED AFTER INSTALLATION AND YEARLY THEREAFTER BY A WASHINGTON STATE CERTIFIED BACKFLOW ASSEMBLY TESTER. TEST RESULTS SHALL BE SENT TO CLARK PUBLIC UTILITIES WATER SERVICES.

REVISED JANUARY 2025

FILE NAME		STANDARD PVBA (PRESSURE VACUUM BREAKER ASSEMBLY) 2" & SMALLER	Clark Public Utilities 
19W			
SHEET	1 OF 1	STANDARD DETAILS	

**ABOVE GROUND
INSTALLATION ONLY**

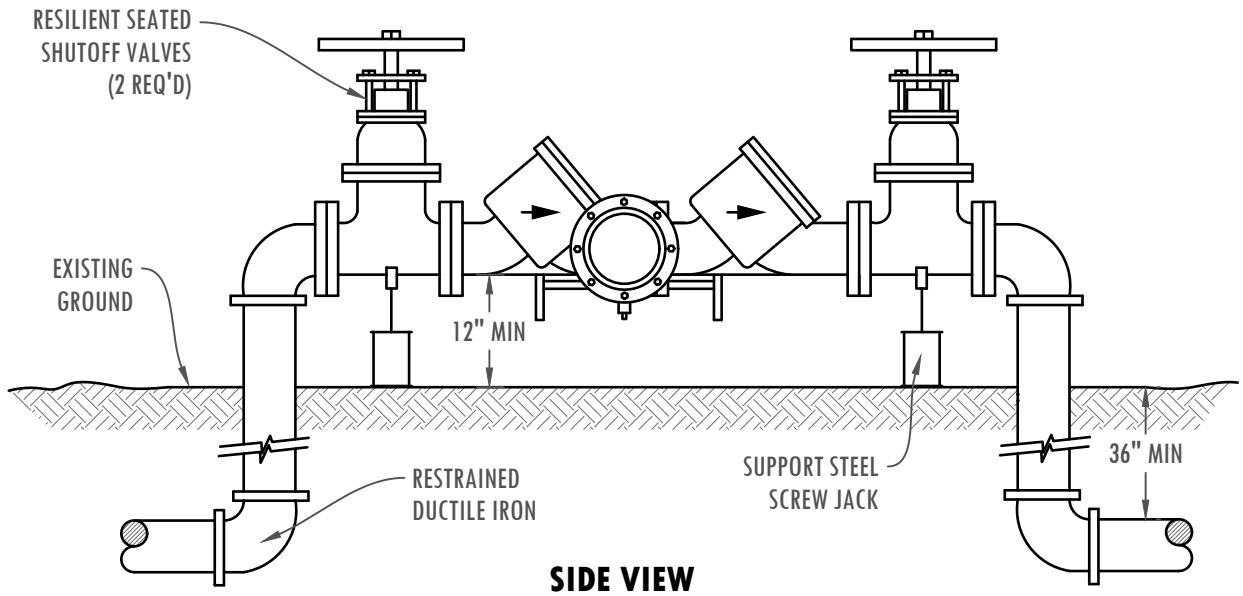
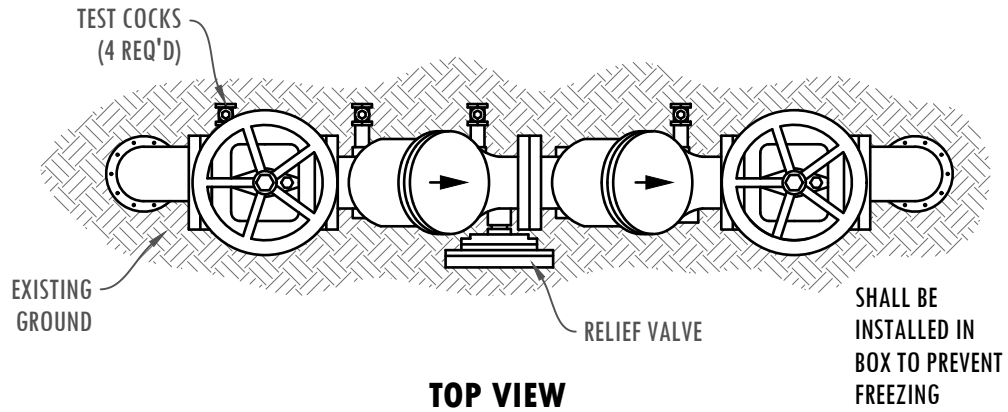

NOTES:

1. APPROVED BACKFLOW ASSEMBLIES TO BE INSTALLED ABOVE GROUND ONLY WITH MINIMUM CLEARANCES.
2. THE BACKFLOW ASSEMBLY SHALL BE A STATE APPROVED MODEL.
3. DESIGNED FOR BACK SIPHONAGE AND BACK PRESSURE.
4. THE WATER LINE SHALL BE DISINFECTED, FLUSHED, AND PRESSURE TESTED PRIOR TO INSTALLING THE BACKFLOW ASSEMBLY.
5. THE BACKFLOW ASSEMBLY SHALL BE PROTECTED FROM FREEZING AND FLOODING INSIDE AN INSULATED BOX COMMONLY REFERRED TO AS A HOT BOX.
6. ALL PIPE, VALVE, AND FITTING JOINTS, FROM THE SUPPLY MAIN, SHALL BE RESTRAINED.
7. THE BACKFLOW ASSEMBLY SHALL BE TESTED AFTER INSTALLATION AND PRIOR TO ACCEPTANCE AND ALSO YEARLY THEREAFTER BY A WASHINGTON STATE CERTIFIED BACKFLOW ASSEMBLY TESTER. TEST RESULTS SHALL BE SENT TO CLARK PUBLIC UTILITIES WATER SERVICES.

REVISED JANUARY 2025

FILE NAME		STANDARD RPBA (REDUCED PRESSURE BACKFLOW ASSEMBLY) 2-1/2" & LARGER	
20W			
SHEET	1 OF 1	STANDARD DETAILS	

**ABOVE GROUND
INSTALLATION ONLY**

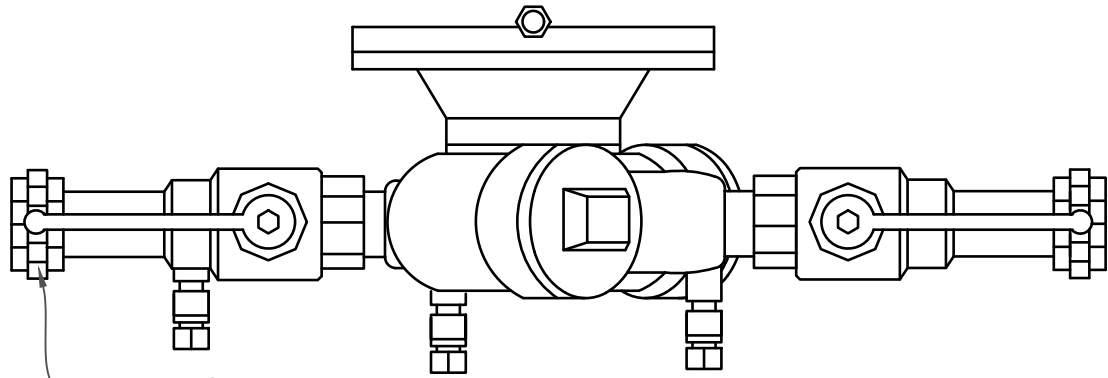

TOP VIEW

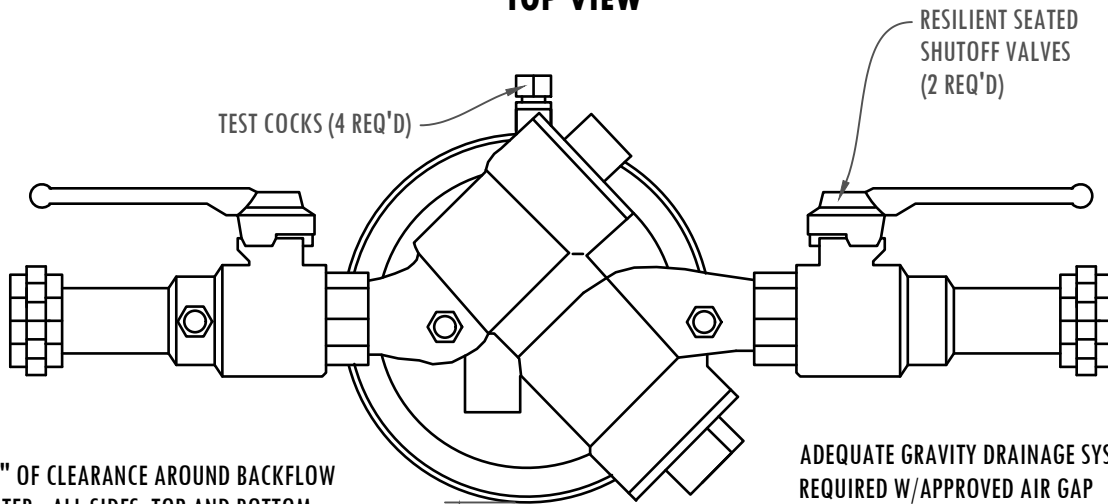

SIDE VIEW

NOTES:

1. APPROVED REDUCED PRESSURE BACKFLOW ASSEMBLY TO BE INSTALLED ABOVE GROUND ONLY WITH MINIMUM CLEARANCES.
2. DESIGNED FOR BACK SIPHONAGE AND BACK PRESSURE.
3. TEST COCKS TO EITHER FACE OUTWARDS OR UPWARDS FROM ASSEMBLY.
4. DISINFECT, PRESSURE TEST AND THOROUGHLY FLUSH LINES PRIOR TO INSTALLATION OF BACKFLOW PREVENTER.
5. DO NOT INSTALL IN AN AREA SUBJECT TO FLOODING.
6. MUST BE PROTECTED FROM FREEZING CONDITIONS INSIDE AN INSULATED BOX COMMONLY REFERRED TO AS A HOT BOX.
7. THE BACKFLOW ASSEMBLY SHALL BE A STATE APPROVED MODEL.
8. A PLUMBING PERMIT IS REQUIRED. PLEASE CONTACT YOUR LOCAL PLUMBING PERMIT CENTER.
9. MUST BE TESTED AFTER INSTALLATION AND YEARLY THEREAFTER BY A WASHINGTON STATE CERTIFIED BACKFLOW ASSEMBLY TESTER. TEST RESULTS SHALL BE SENT TO CLARK PUBLIC UTILITIES WATER SERVICES.

REVISED JANUARY 2025

FILE NAME		STANDARD RPBA (REDUCED PRESSURE BACKFLOW ASSEMBLY) 2" & SMALLER	
21W			
SHEET	1 OF 1	STANDARD DETAILS	

**ABOVE GROUND
INSTALLATION**

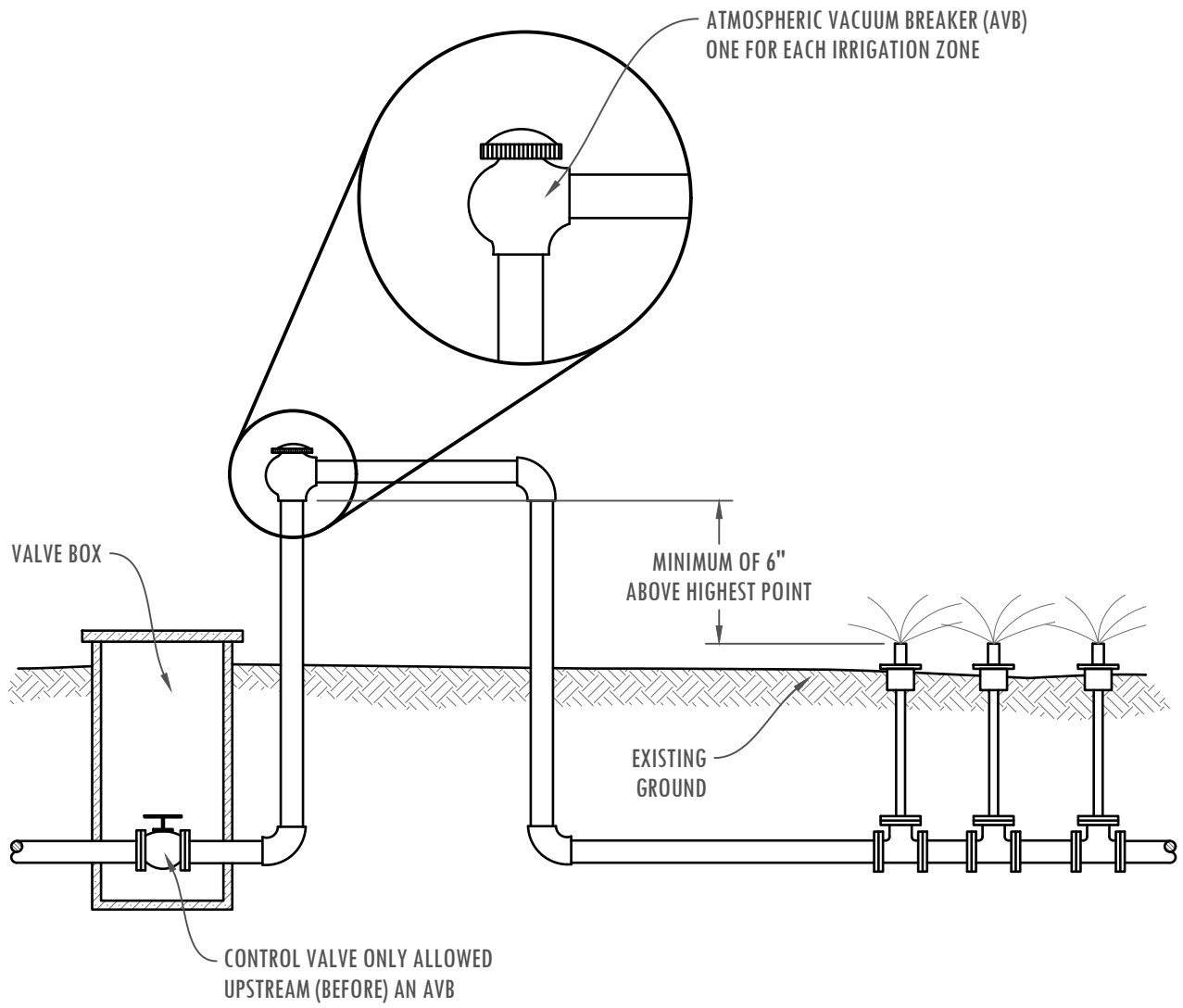

NOTES:

1. ONE AVB IS REQUIRED ON EACH IRRIGATION ZONE. NO CONTROL VALVES ALLOWED DOWNSTREAM (AFTER) AND AVB.
2. EACH AVB MUST BE INSTALLED A MINIMUM OF 6" ABOVE THE HIGHEST POINT OF WATER IN THE ZONE IT SERVES.
3. NO CHEMICAL FERTILIZER MAY BE INTRODUCED INTO AN IRRIGATION SYSTEM EQUIPPED WITH AN AVB.
4. NO PUMPS, AIR FITTINGS OR BACK PRESSURE SOURCE IS ALLOWED ON THE DOWNSTREAM SIDE (AFTER) AN AVB.
5. MUST BE PROTECTED FROM FREEZING BY WRAPPING PIPES WITH HEAT TAPE WIRE.

REVISED JANUARY 2025

FILE NAME		STANDARD AVB (ATMOSPHERIC VACUUM BREAKER)	
22W			
SHEET	1 OF 1	STANDARD DETAILS	

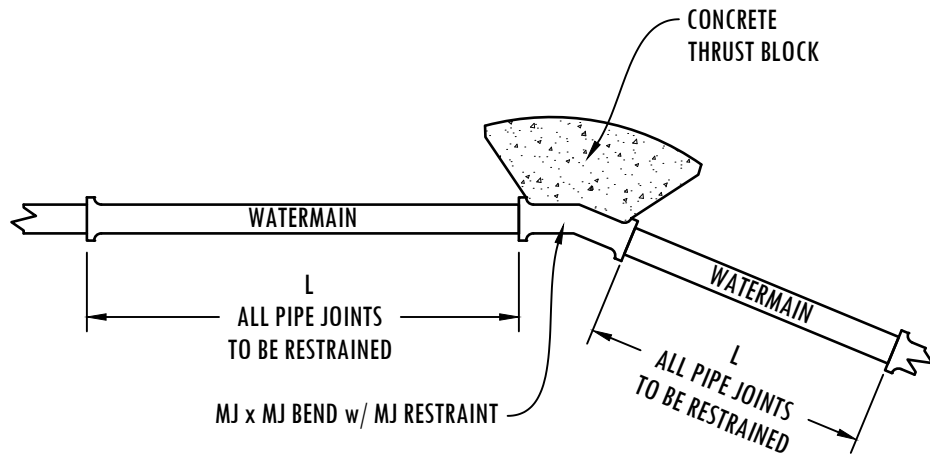

PIPE RESTRAINT LENGTHS					
FITTING	4" DIA PIPE	6" DIA PIPE	8" DIA PIPE	10" DIA PIPE	12" DIA PIPE
	L	L	L	L	L
11-1/4° BEND	3'	3'	4'	5'	6'
22-1/2° BEND	5'	6'	8'	10'	12'
45° BEND	9'	13'	17'	20'	24'
90° BEND	22'	31'	40'	48'	57'

NOTE: THESE ARE THE MINIMUM PIPE RESTRAINT LENGTHS UNLESS STATED OTHERWISE ON THE PLANS. VALUES SHOWN HEREIN ASSUME 200PSI MAX TESTING PRESSURE WITH WELL GRADED GRAVEL BEDDING AND 3' STANDARD COVER.

REVISED JANUARY 2025

FILE NAME		HORIZONTAL BEND WATER MAIN INSTALLATION DETAIL	
23W			
SHEET	1 OF 1	STANDARD DETAILS	

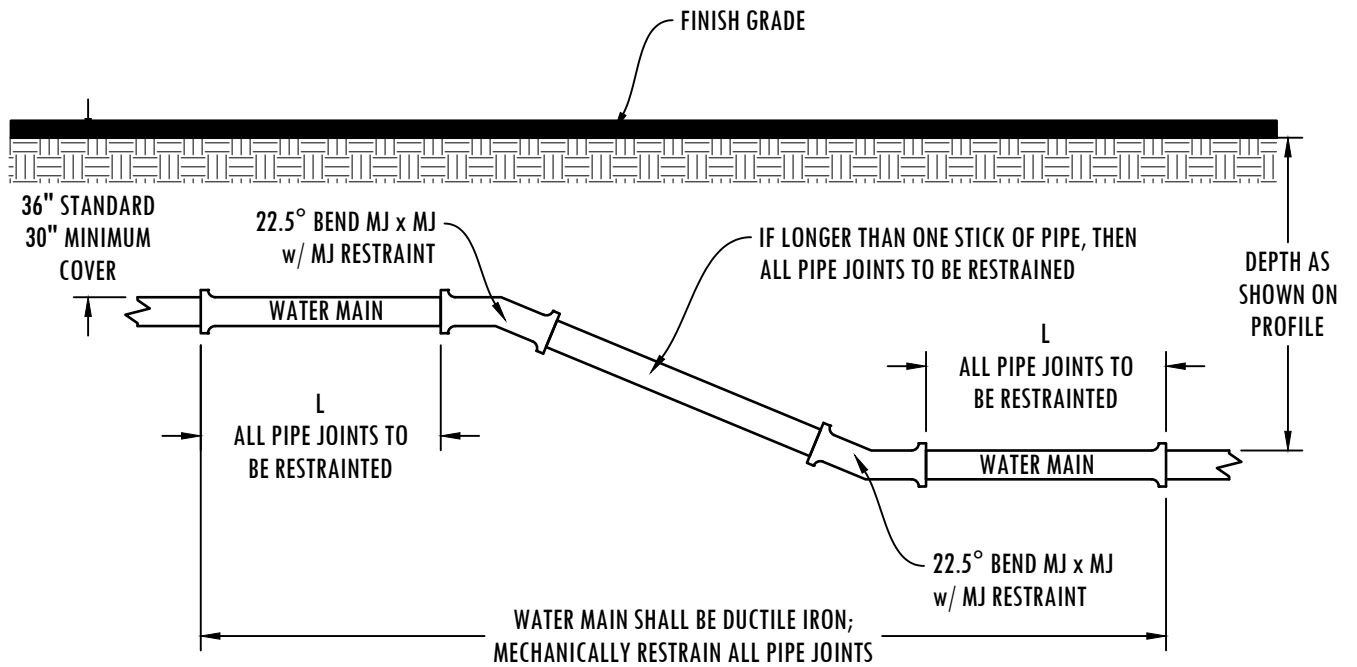

NOTE:

CALL CPU INSPECTOR TWO(2) WORKING DAYS PRIOR TO BE ON-SITE TO OBSERVE. TRENCH BOTTOM SUBGRADE MUST BE FIRM AND UNDISTURBED.
 PIPE BEDDING (5/8"-0: AGG BASE) SHALL BE A MINIMUM OF 6" EACH SIDE AND TOP AND BOTTOM OF PIPE COMPACTED.
 THRUST BLOCKS/ANCHORS NOT SHOWN FOR CLARITY.

PIPE RESTRAINT LENGTHS (WITHOUT POLY BAG ENCASEMENT)					
FITTING	4" DIA PIPE L	6" DIA PIPE L	8" DIA PIPE L	10" DIA PIPE L	12" DIA PIPE L
11-1/4° BEND	6'	9'	11'	12'	16'
22-1/2° BEND	12'	17'	23'	27'	32'

NOTE: THESE ARE THE MINIMUM PIPE RESTRAINT LENGTHS UNLESS STATED OTHERWISE ON THE PLANS.
 45° BENDS NOT ALLOWED FOR VERTICAL INSTALLATION. VALUES SHOWN HEREIN ASSUME 200PSI
 MAX TESTING PRESSURE WITH WELL GRADED GRAVEL BEDDING AND 3' STANDARD COVER.

REVISED JANUARY 2025

FILE NAME		VERTICAL FITTING WATER MAIN INSTALLATION DETAIL	
24W			
SHEET	1 OF 1	STANDARD DETAILS	

PIPE RESTRAINT LENGTHS	
PIPE SIZE	L ₁
4"	36'
6"	53'
8"	71'
10"	86'
12"	103'

NOTE: THESE ARE THE MINIMUM PIPE RESTRAINT LENGTHS UNLESS STATED OTHERWISE ON THE PLANS. VALUES SHOWN HEREIN ASSUME 200PSI MAX TESTING PRESSURE WITH WELL GRADED GRAVEL BEDDING AND 3' STANDARD COVER.

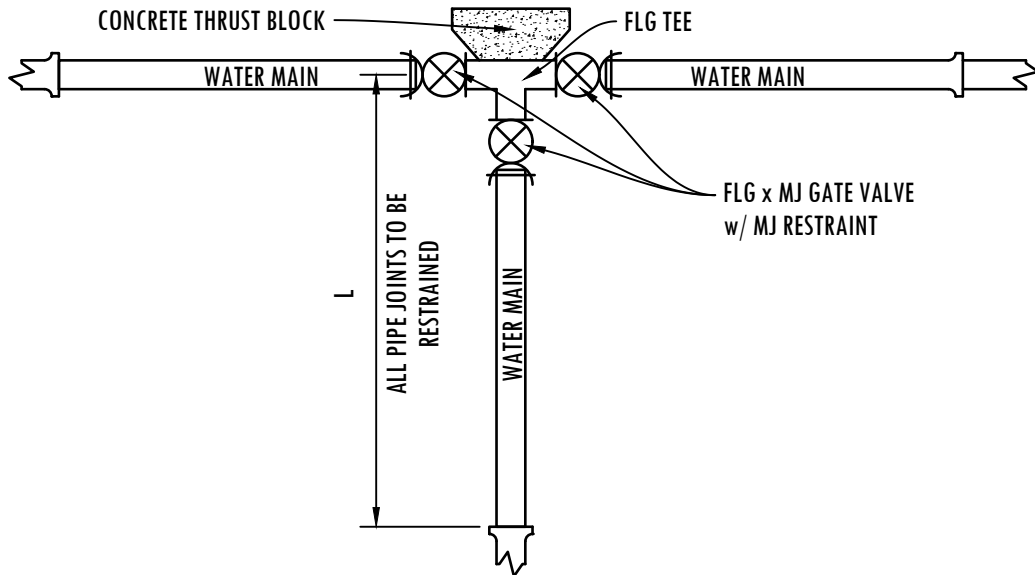

REVISED JANUARY 2025

FILE NAME		TYPICAL FITTING & VALVE INSTALLATION DETAIL	
25W			
SHEET	1 OF 1	STANDARD DETAILS	

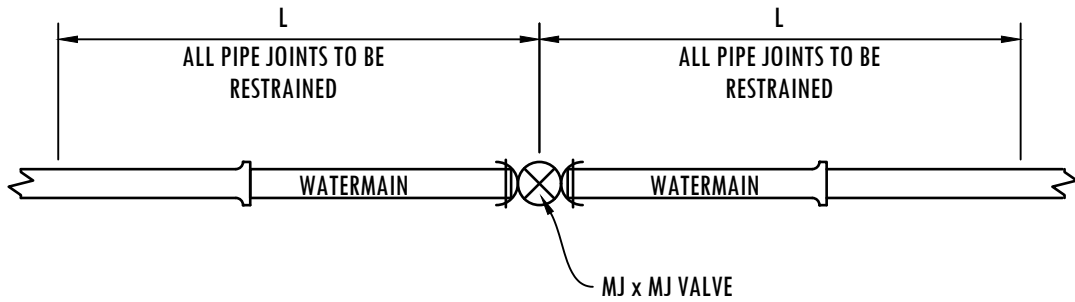

PIPE RESTRAINT LENGTHS	
PIPE SIZE	L
4"	40'
6"	56'
8"	74'
10"	90'
12"	107'

NOTE: THESE ARE THE MINIMUM PIPE RESTRAINT LENGTHS UNLESS STATED OTHERWISE ON THE PLANS. VALUES SHOWN HEREIN ASSUME 200PSI MAX TESTING PRESSURE WITH WELL GRADED GRAVEL BEDDING AND 3' STANDARD COVER.

REVISED JANUARY 2025

FILE NAME		TYPICAL IN-LINE VALVE INSTALLATION DETAIL	
26W			
SHEET	1 OF 1	STANDARD DETAILS	

ALLOWABLE DIP JOINT DEFLECTION			
PIPE SIZE	ALLOWABLE DEFLECTION ANGLE	ALLOWABLE OFFSET "S"	
		PIPE L=18'	PIPE L=20'
6"	3°	11"	12"
8"	3°	11"	12"
12"	3°	11"	12"

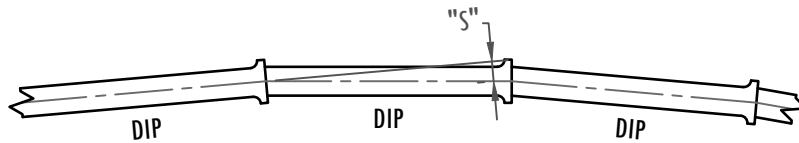

NOTE: DEFLECTIONS IN ALIGNMENT FOR DIP SHALL BE MADE BY DEFLECTING THE PIPE JOINTS PER THE ATTACHED DEFLECTION TABLE

ALLOWABLE PVC PIPE BENDING		
PIPE SIZE	ALLOWABLE MINIMUM BENDING RADIUS	ALLOWABLE OFFSET "S"
6"	200'	12"
8"	250'	9.5"
12"	350'	7"
NO BENDING OF PVC PIPE ALLOWED FOR PIPE LARGER THAN 12" DIAMETER		

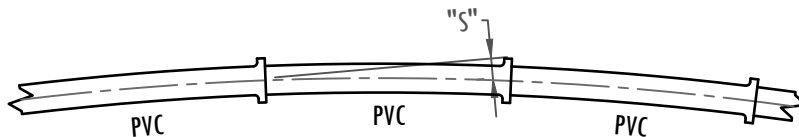

NOTE: DEFLECTIONS IN ALIGNMENT FOR PVC PIPE SHALL BE MADE BY BENDING THE PIPE AND NOT DEFLECTING PIPE JOINTS

REVISED JANUARY 2025

FILE NAME		DUCTILE IRON PIPE DEFLECTION & PVC PIPE BEND DETAIL	
27W			
SHEET	1 OF 1	STANDARD DETAILS	