



## **TECHNICAL SPECIFICATIONS**

**15kV**

**MEDIUM VOLTAGE**

**1/0 105°C EPR 175 MIL**

**ALUMINUM URD CABLE**

**Stock #2390**

February 1995  
Revised March 1996  
Revised March 2005  
Revised May 2007  
Revised April 2017  
Revised March 2020  
Revised May 2020  
Revised October 2020  
Revised January 2024  
Revised December 2024

**15kV MEDIUM VOLTAGE  
1/0 AL 175 MIL URD CABLE  
105°C EPR**

**1.0 GENERAL**

1.1 Description

This specification covers the technical requirements for 15kV medium voltage, 1/0, Al, 175 mil, jacketed, concentric-neutral URD cable. The cable shall consist of one 105°C ethylene propylene rubber (EPR) insulated central conductor with helically applied copper concentric neutral conductors over the insulation shielding, and an overall jacket of black, linear, low-density polyethylene.

1.2 Applications

The cable shall be suitable for use in single, two, and three-phase 15kV underground distribution systems in residential and commercial applications.

1.3 Service Environment & Operating Requirements

1.3.1 The cable shall be suitable for aerial, direct burial, and conduit installations in wet and dry locations with maximum normal operating temperatures to 105°C. The cable shall be suitable for a minimum installation temperature of -10°C without special handling.

1.3.2 The cable shall be designed and constructed such that it will operate satisfactorily at emergency operating temperatures to 140°C and short circuit operating temperatures to 250°C as defined by ICEA S-94-649.

1.4 Language

All dimensions and specifications communicated to CPU shall be in the English language and shall be in customary English units. Metric units and/or other languages are not acceptable.

**2.0 REFERENCE STANDARDS**

Reference is made in this specification to the following standards, the latest editions, amendments, and supplements of which shall apply, unless otherwise stated in this specification or in associated purchasing documents:

AEIC CS-8	<i>Specifications for Extruded Dielectric Shielded Power Cables Rated 5 through 46kV.</i>
ANSI C2	<i>National Electrical Safety Code.</i>
ASTM B231/B231M	<i>Standard Specification for Concentric-Lay-Stranded Aluminum 1350 Conductors</i>
ASTM B609/B609M	<i>Standard Specification for Aluminum 1350 Round Wire, Annealed and Intermediate Tempers, for Electrical Purposes</i>
ICEA S-94-649	<i>Standard for Concentric Neutral Cables Rated 5 through 46kV</i>
ISO-9001	<i>Quality Management Systems – Requirements</i>
NEMA WC 26	<i>Binational Wire and Cable Packaging Standard</i>

### **3.0 MANUFACTURING METHOD**

#### **3.1 Extrusion**

3.1.1 The conductor shielding, insulation, and insulation shielding shall be applied in a triple extrusion process or a two plus one process.

3.1.2 All changes or alterations to the critical process parameters of the extrusion line shall be logged in the production log.

#### **3.3 Curing**

The curing system during extrusion shall be either a nitrogen, inert gas or steam system.

#### **3.4 Cooling**

A moisture-free or water cooling process is acceptable.

### **4.0 CONSTRUCTION**

The compound supplied shall be the same as that qualified in the AEIC-ICEA qualification tests.

#### **4.1 Central Conductor**

The central conductor shall be uncoated aluminum 1350 or 8000 series, stranded as specified by CPU. Aluminum rod from which conductor is drawn shall be free of defects and corrosion, cleaned of oil and contaminants, and purged of cleaning solvents prior to the drawing process. The conductor surface shall be smooth.

##### **4.1.1 Stranded Conductor**

Stranded conductor shall be 8000 series or 1350-H19 or less hard, class B concentric lay, and compressed 3% maximum, in accordance with ASTM B609 and ASTM B231.

##### **4.1.2 Strand-Block**

Stranded conductor may contain a strand-block material in the interstices of the conductor in accordance with ANSI/ICEA S-94-649-2021, Part 2.3. The strand-block material shall be flexible, stable and compatible with the cable components and commonly used cable accessories which may encounter the compound. The outer surface of the conductor shall be clean and free of strand-block material. No water absorbing powders will be accepted. A sample of conductor with strand-block material shall be reviewed by CPU prior to first time acceptance. Any changes to the strand-block will need to be reviewed by CPU.

#### **4.2 Conductor Shielding**

4.2.1 The conductor shielding shall be a black, extruded, thermosetting, semiconducting or stress-grading material which is compatible with all the materials coming in contact

## Technical Specifications for 15kV Medium Voltage 1/0 EPR 175mil Al URD Cable

with it. The outer surface of the conductor shielding shall be firmly bonded to the overlying insulation. The shielding shall be easily removable from the conductor. The shielding shall not penetrate past the center of the outside strand layer.

4.2.2 The physical and electrical properties of the conductor shield shall be in accordance with the requirements of ICEA S-94-649.

### 4.3 Insulation

4.3.1 The insulation compound shall be ethylene propylene rubber based material and contain no more than 72% ethylene by weight and less than 1% polyethylene by weight.

4.3.2 The insulation shall be extruded directly over and firmly bonded to the conductor shielding.

4.3.3 The minimum point insulation thickness shall be 165 mils. The maximum point insulation thickness shall be 205 mils.

### 4.4 Insulation Shielding

4.4.1 The insulation shielding shall consist of a black, extruded, thermosetting, semiconducting, or stress control layer of polymeric material extruded directly over the insulation. The material shall be completely compatible with the insulation.

4.4.2 The insulation shielding shall be readily distinguishable from the insulation and shall be legibly identified as semiconducting or stress control layer by means other than indent printing.

4.4.3 The minimum and maximum thickness of the insulation shielding shall be in accordance with ICEA S-94-649.

4.4.4 The physical and electrical properties of the insulation shield shall be in accordance with ICEA S-94-649.

### 4.5 Full Copper Concentric Neutral

4.5.1 A concentric neutral conductor consisting of round annealed, uncoated copper wires in accordance with ICEA S-94-649, shall be applied helically over and in contact with the insulation shielding.

4.5.2 The conductivity of the concentric neutral shall be a full neutral. The number and size of concentric neutral wires shall be as shown in ICEA S-94-649, Table 6-2.

### 4.6 Overall Outer Jacket

The overall outer jacket shall consist of a black, linear, low-density polyethylene compound. The jacket shall be nonconducting. The jacket shall be an extruded-to-fill type.

4.6.1 The nonconducting jacket shall meet the physical and aging requirements of ICEA S-94-649.

- 4.6.2 The cable shall be manufactured such that the concentric neutral wires are equally spaced and remain in contact with the underlying extruded insulation shielding after application of the overall jacket.

## **5.0 CABLE IDENTIFICATION**

- 5.1 The center strand of stranded conductor cable shall be indent printed with the manufacturer's name and year of manufacturer at regular intervals with unindented surfaces not exceeding 12 inches.
- 5.2 The outer surface of the jacket of each cable shall be durably and legibly marked throughout its length in accordance with ICEA S-94-649 including month and year of manufacturing, and additionally, a lightning bolt symbol (in accordance with ANSI C2). Identification marking shall be of the indent-printing type. The depth of the indentation shall not result in the violation of the minimum jacket thickness as required by ICEA S-94-649.
- 5.3 Sequential footage numbers shall be clearly printed throughout the cable length at 2-foot intervals. Sequential footage numbers shall not be repeated on any single order. Sequential footage numbers may be of the indent-printing type with the indentation highlighted with white or silver colored ink or surface printed. The depth of the indentation shall not result in the violation of the minimum jacket thickness as required by ICEA S-94-649.
- 5.4 The outer surface of the jacket of each cable shall be marked with three (3) extruded, continuous, longitudinal, highly visible opaque red stripes spaced 120° apart. The nominal dimensions of the stripes shall be in accordance with ICEA S-94-649.

## **6.0 QUALITY ASSURANCE**

### **6.1 Quality System**

The cable manufacturer shall have a quality system in place that meets the requirements of ISO-9001.

### **6.2 Plant Certification**

To qualify as a bidder, the following information shall be submitted for the specific cable manufacturing plant where the cable will be made:

6.2.1 Plant location.

6.2.2 Description of the extrusion equipment used, including positioning of extruders.

6.2.3 Description of the curing process and equipment used.

6.2.4 Description of the cooling down process used.

6.2.5 Description of the compound inspection process used.

## Technical Specifications for 15kV Medium Voltage 1/0 EPR 175mil Al URD Cable

6.2.6 Description of the compound handling system used from the shipping vehicle to the extruder.

6.2.7 Description of the statistical quality control method used.

6.2.8 List of five previous customers supplied from this plant with contact names and telephone numbers.

### **7.0 TESTING AND TEST METHODS**

#### 7.1 Qualification Tests

One certified copy of the results of ICEA S-94-649, and AEIC CS8 qualification tests on specified cable shall be provided. Cable with a number 1/0 conductor size is the preferred size for the qualification tests.

#### 7.2 Production Sampling Tests

Production sampling tests shall be made in accordance with ICEA S-94-649.

#### 7.3 Production Run Certified Test Reports (CTR)

##### 7.3.1 General Requirements

The following general information shall be included in the CTR: plant identification, process description, CTR number, purchase order number, manufacturer shipment number, reel count, shipment footage, cable core extruder/CV line identifier, and jacket line identifier. The CTR shall list the compound, and the facility where the compound was manufactured and where it was mixed. Any changes or modifications made to the compounds shall be noted in the CTR.

##### 7.3.2 Measurement Data

The following CTR production run data shall be provided for all cable produced: minimum point thickness for the conductor shield; the minimum and maximum point thickness for the insulation, insulation shield and jacket; minimum diameter and maximum diameter for the insulation and insulation shielding. This production run data shall be provided for each shipping reel and shall be traceable to the production log.

#### 7.4 Tests on Completed Cables

Tests on completed cable and partial discharge test shall be made in accordance with ICEA S-94-649.

### **8.0 ACCEPTANCE TESTS**

#### 8.1 Shipping and Labeling Requirements

The cable manufacturer shall email the reports identified in Section 8.2 Shiree Smith, Senior Buyer, at [ssmith@clarkpud.com](mailto:ssmith@clarkpud.com).

## 8.2 Report and Sample Requirements

One certified copy of the reports of all test data and dimensional measurements, including X-Y plots when appropriate, shall be furnished for each master reel of cable to be shipped.

## 8.3 Sampling by the Utility

A twenty-four inch sample shall be available on the inner end of each cable reel. The sample shall be an extension of the cable through the reel flange and stapled to the flange.

## 8.4 Performance Acceptance Tests

Performance acceptance tests may be conducted on samples from each reel of cable to be accepted based on the procedures contained in this specification. The testing and examinations of cable samples may be performed by the utility or its authorized agent. All test procedures, examinations, and their results shall conform to ICEA S-94-649 except as specifically noted. Failure of a sample to satisfy the requirements of any section of this specification may be cause for rejection of that shipping reel of cable. Clark Public Utilities or its authorized representative reserves the right to refuse installation of any cable not meeting the requirements of this specification.

## 8.5 Tests that May be Performed on 24 Inch Cable Samples

8.5.1 The cable jacket may be visually inspected for correct markings and any surface damage to the cable jacket.

8.5.2 The cable jacket may be measured to determine the minimum and maximum thickness.

8.5.3 With the jacket removed, the copper concentric neutral wires may be examined for defects, uniformity of spacing around the cable, and lay. The number of strands may be counted and the wire size measured.

8.5.4 With the copper concentric neutral wires removed, the insulation shield may be visually inspected for correct markings and surface damage. The volume resistivity and the bond strength (or stripping tension) may be measured.

8.5.5 With the insulation shield removed, the insulation may be visually inspected for contaminants, voids, and protrusions. Any questionable areas may have wafer samples taken which may be examined.

8.5.6 The volume resistivity of the semiconducting conductor shield may be measured.

8.5.7 The conductor may be inspected for manufacturer identification, lay, protrusions, and defects. The outside diameter of the conductor may be measured. The number of strands may be counted and measured for wire size.

## **9.0 SHIPMENT AND REELS**

### **9.1 Packing and Sealing**

9.1.1 Cable shall be supplied in one continuous length for each reel. Length shall be +5% to 0% of the length specified for each reel.

9.1.2 Each end of the cable shall be firmly and properly secured to the reel. Care shall be taken to prevent looseness of reeled cable. The cable end attached through the interior of the reel shall be fastened in such a manner that it remains attached as the cable is dispensed from the reel and does not interfere with other reels or waste cable. See CPU's Reel Specifications drawing, UCH-2.

9.1.3 There shall be a minimum 2-inch clearance between the outer edge of the reel flange and the surface of the outermost layer of cable.

9.1.4 Watertight seals shall be applied to all cable ends to prevent entry of moisture during transit and outside storage prior to installation.

### **9.2 Reels**

Unless otherwise specified, all reels shall:

- Be un-used, new, non-returnable wood reels constructed as per NEMA WC 26 Table 2-5 – *Heavy Duty Reusable Wood Reels Class 2*.
- Be free of damaging protrusions, e.g., nails, staples, etc.
- Use steel bushings to line reel arbor holes.
- Have a minimum drum diameter of 24 cable diameters.
- Have a maximum flange diameter of 58 inches.

### **9.3 Reel Coverings**

To provide physical protection for cable during normal transit, storage and handling, conductors on reels shall be covered with a Level 2 Weather protector over the outer layer of conductor in accordance with NEMA WC 26-2008, Section 4.1.

### **9.4 Marking on Reels**

Reel information shall be embossed on stainless steel or aluminum tags permanently attached to the outside of the reel. Paper reel tags even if glued to a metal backing are not acceptable. The manufacturer shall label each reel as follows:

- Manufacturer's name, shipping reel number, factory reel number, and/or any other information to determine the origin of the cable.
- Purchaser's purchase order number
- Net weight, gross weight, and tare weight
- Length of cable
- Beginning and ending sequential footage numbers
- Type of cable
- Type, size, and stranding of conductor
- Thickness and type of insulation



## Technical Specifications for 15kV Medium Voltage 1/0 EPR 175mil Al URD Cable

- Voltage rating of cable
- Date of manufacturer and location
- DO NOT UPEND. Minimum 2 inches high, bright red or orange. An appropriate symbol such as a reel on its side with a red circle around it and a diagonal line through it is acceptable.
- All reels shall be traceable to the production log.

### 9.5 Shipping Instructions

The cable shall be shipped on flat bed vehicles. Enclosed vans will be rejected. The cable shall be shipped with the reel flanges vertically oriented. The reels must be secured to prevent flanges of one reel from damaging the cable on another reel. Reels shipped in enclosed trucks, lying horizontally on the flange, or stacked more than one high will be rejected.

### 10.0 WARRANTY

The vendor warrants that the cable furnished is free from defects in material and workmanship for a period of not less than 40 years and agrees to replace any material that is unsuitable for operation or fails in operation during normal and proper use.

### 11.0 BID REQUIREMENTS

11.1 The bid shall clearly identify all compounds, the supplier name, plant location, and any modifications to the compounds.

11.2 The bid shall include plant certification as outlined in Section 6.2 of the technical specifications.

11.3 The bid shall include a history of in-service records and a history of the proposed compound.

11.4 The bid shall include the manufacturer's most current written copies of the following:

- (a) The certified copy of the AEIC - ICEA Qualification Test report for the compounds, materials, design, and processes which are to be used in manufacturing the specified cable.
- (b) Procedures covering repair or rework of the layers outside of the cable core.
- (c) Procedures, including examples, of production run sample selection, wafer selection, and wafer dimensional data recording.
- (d) Procedures for re-sampling, hold tagging, and scrapping of portions of the cable run.

11.5 The bid shall include a bid data sheet for each item and any alternates.

11.6 ANY BID THAT DOES NOT CONTAIN ALL OF THE INFORMATION REQUESTED IN 11.1 THROUGH 11.5 WILL NOT BE EVALUATED.

**15KV 1/0 EPR 175MIL URD ALUMINUM CABLE  
 BID DATA SHEET**

Manufacturer \_\_\_\_\_ Bid Number \_\_\_\_\_

Phase Conductor size \_\_\_\_\_ Neutral Wire Size & Quantity \_\_\_\_\_

<u>Item</u>	<u>Description</u>	<u>Guaranteed Values</u>
1.	Outside diameter <u>range</u> of cable (complete).	_____
2.	Diameter <u>range</u> over insulator shield	_____
3.	Diameter <u>range</u> over insulation.	_____
4.	Type of stranding.	_____
5.	Nominal weight of completed cable. (lbs/ft)	_____
6.	Type of insulation.	_____
7.	Thickness <u>range</u> of insulation.	_____
8.	Thickness <u>range</u> of insulation shield.	_____
9.	Thickness <u>range</u> of conductor shield.	_____
10.	Reel size (Flange x Traverse x Drum – Max Width outside flange) (in inches) _____ x _____ x _____ - _____	
11.	Length of cable on reel.	_____
12.	Metal Content in lbs/kft	Aluminum _____ Copper _____
13.	Insulation shield (see 4.4.). Stripping tensions at room temperature.	_____ / _____
	Stripping tensions at 32° F.	_____ / _____
	Stripping tensions at 100° F.	_____ / _____
	Insulation shield compound and identification.	_____
14.	Conductor shield compound and identification.	_____
15.	Conductor alloy and temper.	_____
16.	Ethylene content, % by weight.	_____
17.	Polyethylene content, % by weight.	_____
18.	Dissipation Factor at room temperature	_____
19.	S.I.C. at room temperature	_____
20.	Warranty (include the entire warranty on separate sheets.)	

# CLARK PUBLIC UTILITIES REEL SPECIFICATIONS

- \* LEVEL 2 REEL COVERING (NEMA WC 26-2008, SECTION 4.1)
- \* WIRE TO BE PLACED ON REEL WITH EXPOSED TAIL TO UNREEL AS FOLLOWS:

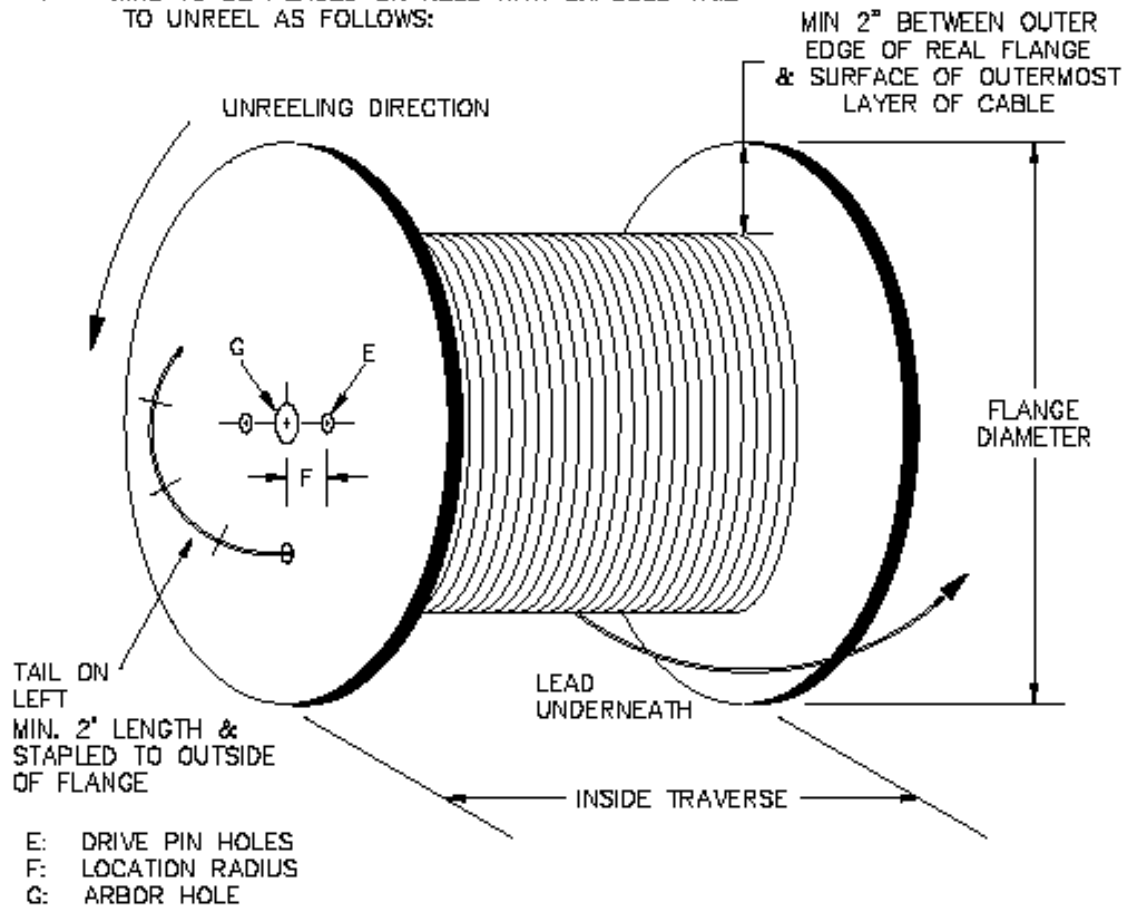

## CONSTRUCTION STANDARDS REEL SPECIFICATIONS

REVISIONS			
DATE	ENGR	OPS	

PAGE  
1 of 1

UCH-2

CAD FILE:  
kUCH2

APP:  
DATE:

SECTION:  
1300