

TYPE 'C' PAVEMENT SECTION

TYPE 'C-1'
 (COLLECTOR OR ARTERIAL)
 0.50' A.C.P. OVER
 0.80' OF 1-1/4" MINUS C.S.B.C.

TYPE 'C-2'
 (RESIDENTIAL)
 0.35' A.C.P. OVER
 0.20' OF 5/8" MINUS C.S.T.C. OVER
 0.80' 1-1/4" MINUS C.S.B.C.

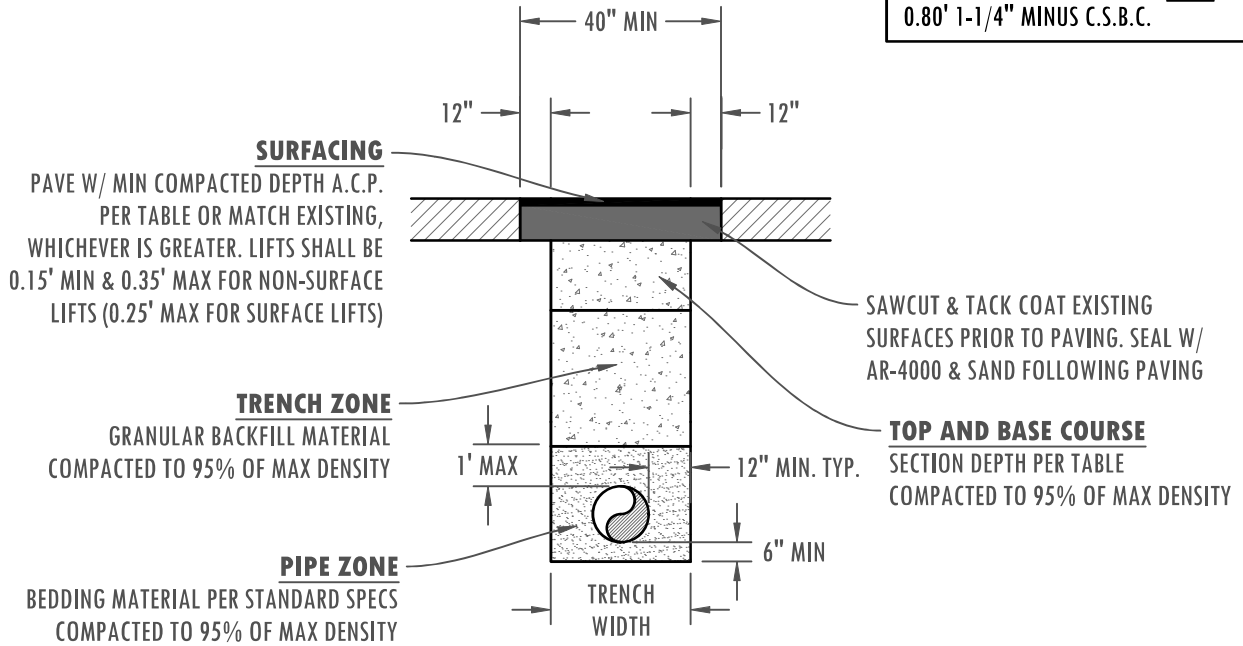

TRENCHING NOTES:

1. SEE CLARK COUNTY OR WSDOT UTILITY PERMIT, WHICHEVER IS APPLICABLE, FOR ADDITIONAL TRENCH BACKFILL AND SURFACING REQUIREMENTS.
2. NATIVE MATERIALS MAY BE SUBSTITUTED FOR IMPORTED GRANULAR MATERIAL PROVIDING IT IS PRE-APPROVED BY THE COUNTY ENGINEER OR AUTHORIZED REPRESENTATIVE.
3. TRENCH EXCAVATION, BEDDING, AND BACKFILL FOR WATER MAINS SHALL BE IN ACCORDANCE WITH SECTION 7-09 OF THE MOST CURRENT STANDARD SPECIFICATIONS. BED PIPE PER SUBSECTION 7-09.3(9) OF THE STANDARD SPECIFICATIONS.
4. IN THE TRENCH ZONE, USE METHOD C COMPACTION PER SECTION 2-03.3(14).
5. PIPE BEDDING (5/8"-0; AGG. BASE) SHALL BE A MINIMUM OF 12" EACH SIDE OF PIPE COMPACTED.

REVISED JANUARY 2025

FILE NAME		ASPHALT CONCRETE PAVEMENT TYPE 'C1' & 'C2' RESTORATION	
12W			
SHEET	1 OF 1	STANDARD DETAILS	