

**BELOW GROUND  
INSTALLATION**

A CLARK PUBLIC UTILITIES  
APPROVED VALVE AND  
WATER MAIN IS REQUIRED  
BETWEEN THE SUPPLY  
MAIN AND THE VAULT

DI FLANGE ADAPTER  
W/ SET SCREW TO  
PROVIDE THRUST  
RESTRAINT AGAINST  
CONCRETE VAULT

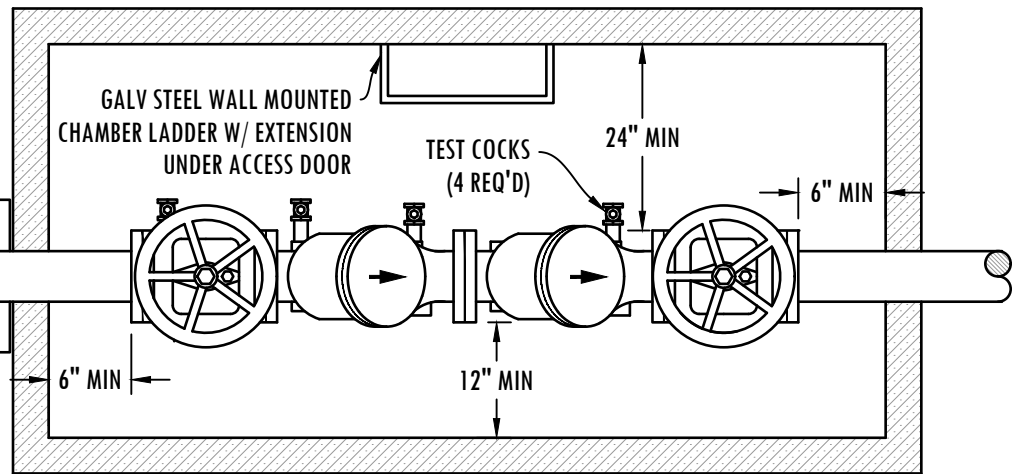

**TOP VIEW**

VAULT SHALL BE EQUIPPED W/ 36" x 36" SPRING  
ASSISTED, HOT DIPPED GALV DIAMOND PLATE  
DOOR. UTILITY VAULT #332P-MODEL 1980.

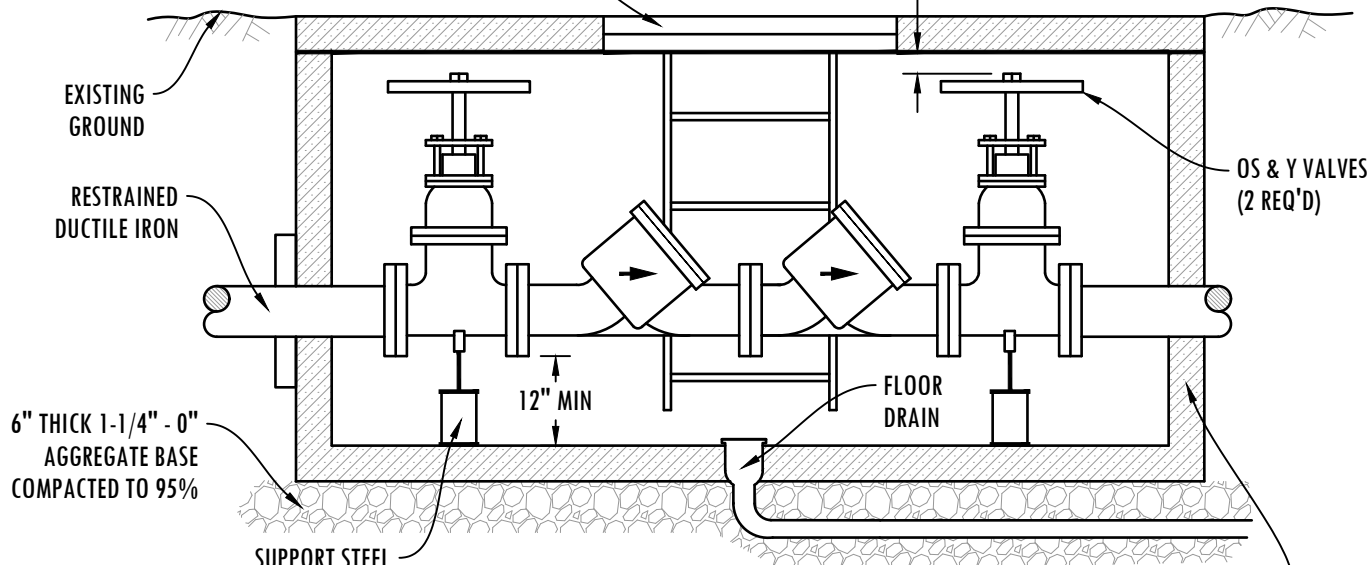

**SIDE VIEW**

**NOTES:**

1. APPROVED DOUBLE CHECK VALVE ASSEMBLY TO LAY HORIZONTAL WITH THE GROUND.
2. DESIGNED FOR BACK SIPHONAGE AND BACK PRESSURE.
3. THE WATER LINE SHALL BE DISINFECTED, FLUSHED, AND PRESSURE TESTED PRIOR TO INSTALLING THE BACKFLOW ASSEMBLY. THE BACKFLOW ASSEMBLY SHALL BE PROTECTED FROM FREEZING AND FLOODING.
4. THE D.C.V.A. MAY BE INSTALLED ABOVE OR BELOW GROUND PROVIDED ALL CLEARANCES ARE MET.
5. ALL PIPE, VALVE, AND FITTING JOINTS, FROM THE SUPPLY MAIN, SHALL BE RESTRAINED.
6. FIRE DEPT. CONNECTION SHALL NOT EXIT THROUGH THE TOP OF THE VAULT.
7. GROUT PIPE ENTRANCE AND EXIT, IN VAULT, WITH WATER-TITE GROUT.
8. ALL VAULTS SHALL BE PRE-APPROVED PRIOR TO INSTALLATION.
9. VAULTS SHALL BE INSTALLED AT PROPERTY LINE OR EASEMENT LINE AND ON OWNERS PROPERTY.
10. VAULTS SHALL HAVE A MINIMUM OF 3' CLEARANCE FROM ALL STRUCTURES.
11. THE BACKFLOW ASSEMBLY SHALL BE TESTED AFTER INSTALLATION AND PRIOR TO ACCEPTANCE AND ALSO YEARLY THEREAFTER BY A WASHINGTON STATE CERTIFIED BACKFLOW ASSEMBLY TESTER. TEST RESULTS SHALL BE SENT TO CLARK PUBLIC UTILITIES WATER SERVICES.

REVISED FEBRUARY 2023

<b>FILE NAME</b>		<b>STANDARD DCVA (DOUBLE CHECK VALVE ASSEMBLY) 2-1/2" &amp; LARGER</b>	<b>Clark Public Utilities</b> 
<b>17W</b>			
<b>SHEET</b>	<b>1 OF 1</b>	<b>STANDARD DETAILS</b>	