

**BELOW GROUND
INSTALLATION**

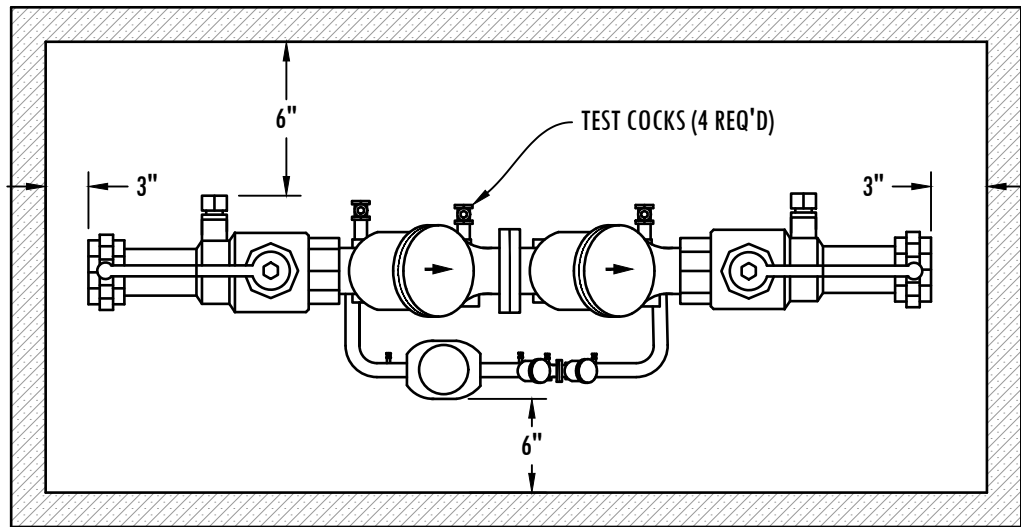

TOP VIEW

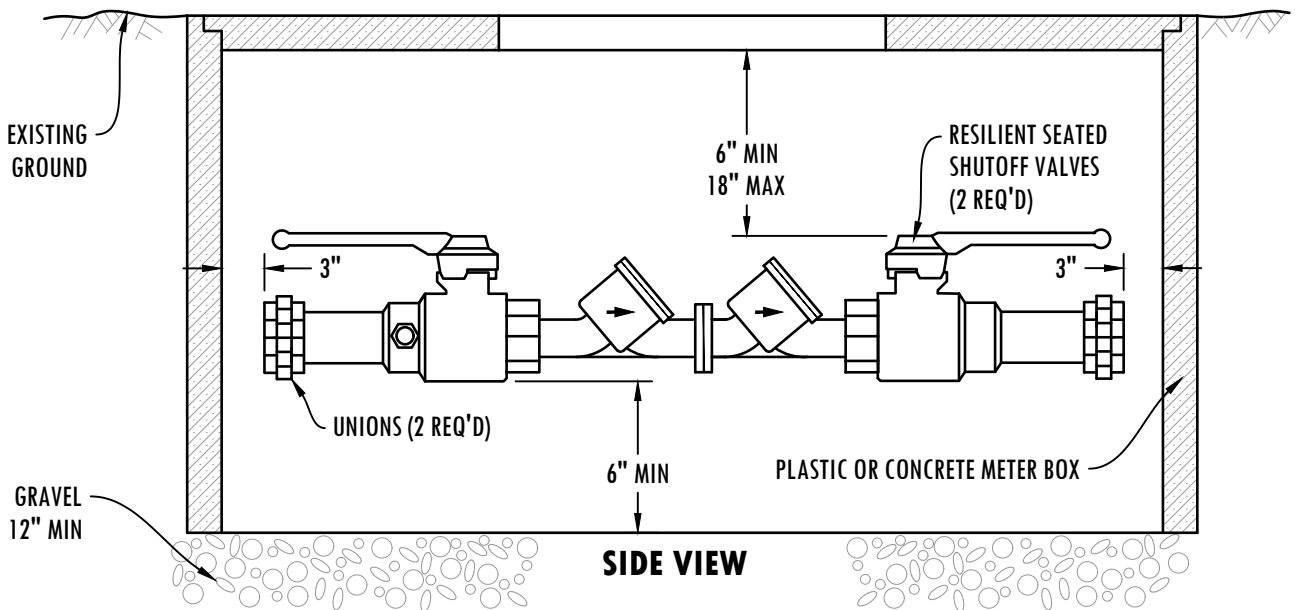

SIDE VIEW

NOTES:

1. APPROVED DOUBLE CHECK DETECTOR ASSEMBLY TO LAY HORIZONTAL WITH GROUND.
2. DESIGNED FOR BACK SIPHONAGE AND BACK PRESSURE.
3. TEST COCKS TO EITHER FACE OUTWARDS OR UPWARDS FROM ASSEMBLY.
4. DISINFECT, PRESSURE TEST AND THOROUGHLY FLUSH LINES PRIOR TO INSTALLATION OF BACKFLOW PREVENTER.
5. THE DCDA MAY BE INSTALLED ABOVE OR BELOW THE GROUND PROVIDED ALL CLEARANCES ARE MET
6. DO NOT INSTALL IN AN AREA SUBJECT TO FLOODING.
7. MUST BE PROTECTED FROM FREEZING CONDITIONS.
8. THE BACKFLOW ASSEMBLY SHALL BE A STATE APPROVED MODEL.
9. A PLUMBING PERMIT IS REQUIRED. PLEASE CONTACT YOUR LOCAL PLUMBING PERMIT CENTER.
10. MUST BE TESTED AFTER INSTALLATION AND YEARLY THEREAFTER BY A WASHINGTON STATE CERTIFIED BACKFLOW ASSEMBLY TESTER. TEST RESULTS SHALL BE SENT TO CLARK PUBLIC UTILITIES WATER SERVICES.

REVISED FEBRUARY 2023

FILE NAME		STANDARD DCDA (DOUBLE CHECK DETECTOR ASSEMBLY) 2" & SMALLER	Clark Public Utilities 
16W			
SHEET	1 OF 1	STANDARD DETAILS	