

**BELOW GROUND
INSTALLATION**

A CLARK PUBLIC UTILITIES APPROVED VALVE AND WATER MAIN IS REQUIRED BETWEEN THE SUPPLY MAIN AND THE VAULT

DI FLANGE ADAPTER W/ SET SCREW TO PROVIDE THRUST RESTRAINT AGAINST CONCRETE VAULT

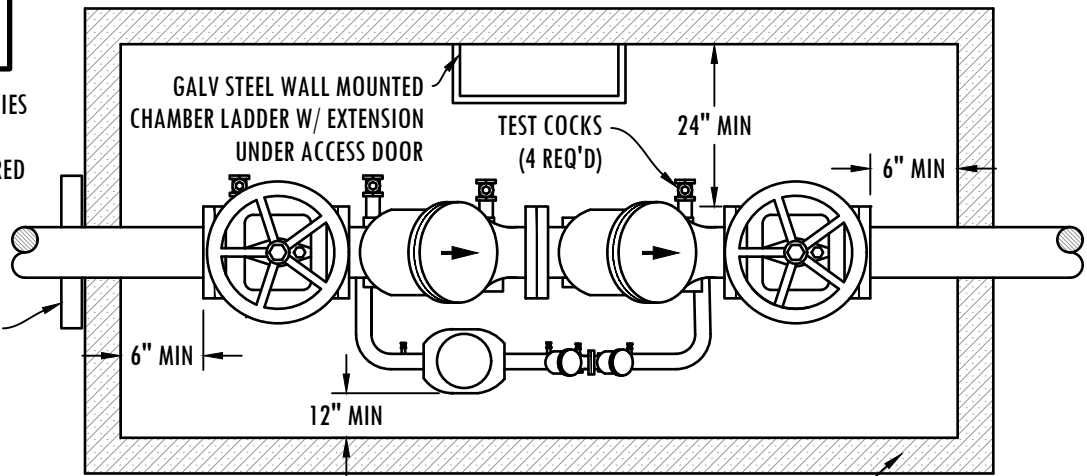

TOP VIEW

VAULT SHALL BE EQUIPPED W/ 36" x 36" SPRING ASSISTED, HOT DIPPED GALV DIAMOND PLATE DOOR. UTILITY VAULT #332P-MODEL 1980.

PRE-CAST CONCRETE VAULT H-20 LOADING W/ LADDER UTILITY VAULT #577-LA

3" MIN WHEN VALVE IS FULLY OPEN

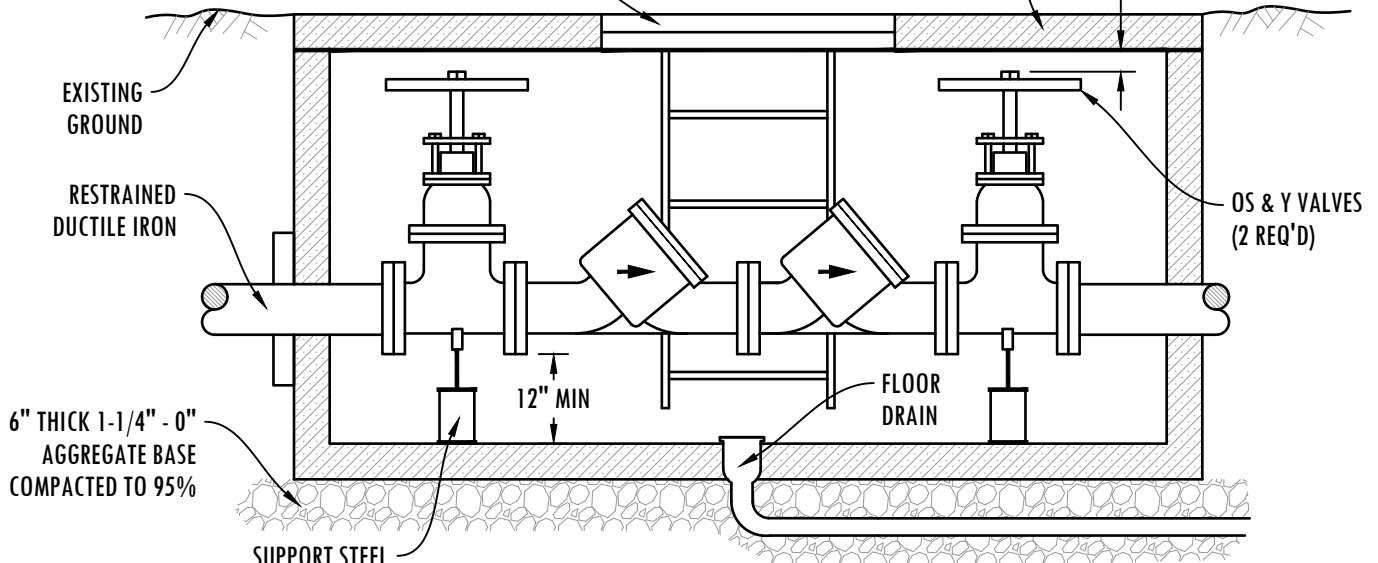

SIDE VIEW

NOTES:

1. APPROVED DOUBLE CHECK DETECTOR ASSEMBLY TO LAY HORIZONTAL WITH THE GROUND.
2. DESIGNED FOR BACK SIPHONAGE AND BACK PRESSURE.
3. THE WATER LINE SHALL BE DISINFECTED, FLUSHED, AND PRESSURE TESTED PRIOR TO INSTALLING THE BACKFLOW ASSEMBLY. THE BACKFLOW ASSEMBLY SHALL BE PROTECTED FROM FREEZING AND FLOODING.
4. THE D.C.D.A. MAY BE INSTALLED ABOVE OR BELOW GROUND PROVIDED ALL CLEARANCES ARE MET.
5. ALL PIPE, VALVE, AND FITTING JOINTS, FROM THE SUPPLY MAIN, SHALL BE RESTRAINED.
6. FIRE DEPT. CONNECTION SHALL NOT EXIT THROUGH THE TOP OF THE VAULT.
7. GROUT PIPE ENTRANCE AND EXIT, IN VAULT, WITH WATER-TITE GROUT.
8. ALL VAULTS SHALL BE PRE-APPROVED PRIOR TO INSTALLATION.
9. VAULTS SHALL BE INSTALLED AT PROPERTY LINE OR EASEMENT LINE AND ON OWNERS PROPERTY.
10. VAULTS SHALL HAVE A MINIMUM OF 3' CLEARANCE FROM ALL STRUCTURES.
11. THE BACKFLOW ASSEMBLY SHALL BE TESTED AFTER INSTALLATION AND PRIOR TO ACCEPTANCE AND ALSO YEARLY THEREAFTER BY A WASHINGTON STATE CERTIFIED BACKFLOW ASSEMBLY TESTER. TEST RESULTS SHALL BE SENT TO CLARK PUBLIC UTILITIES WATER SERVICES.

REVISED FEBRUARY 2023

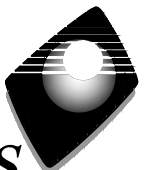
FILE NAME		STANDARD DCDA (DOUBLE CHECK DETECTOR ASSEMBLY) 2-1/2" & LARGER	Clark Public Utilities 
15W			
SHEET	1 OF 1	STANDARD DETAILS	