

900 METERS

11/15/2010

C	M	Metering Requirements - General, Commercial & Residential
C	M1	Primary Metering Installation - OH to UG - 7.2kV, Wye - 3 Element Meter
C	M1A	Primary Metering Installation - OH - 7.2kV, Wye - 3 Element Meter
C	M4	Primary Metering Installation - OH to UG - 7.2kV, 1 Phase, 1 Element Meter
C	M4A	Primary Metering Installation - OH - 7.2kV, 1 Phase, 1 Element Meter
~	M7	Underground Primary Metering Pad - 1 Phase - 200 Amp
C	M8	Underground Primary Metering Pad - 3 Phase - 200 and 600 Amp
~	M16	Secondary Metering Installation - Pole Mounted - 3 Phase, 4 Wire
~	M17	Secondary Metering Installation - Pole Mounted - 1 Phase, 3 Wire
~	M20	Pad & Assembly - Secondary Metering for Padmount Transformer
~	M23	D/I CT Metering at Padmount Transformer
~	M28	Recommended Layout for Temporary Electric Service - 120/240v - 3 Wire
~	M28A	Recommended Conductor Supports for Temporary Electric Service
~	MBCT	CT Meter Base Support for Padmount Transformer
~	UM1	Primary 3 Phase Metering Enclosure
~	UMS4-36	Secondary 1Ø CT Metering Assemblies Residential

N	New Standard
R	Redrawn Standard
C	Changed Standard
~	No Change

CLARK PUBLIC UTILITY

METERING REQUIREMENTS BASED ON EUSERC SPECIFICATIONS

TYPE OF SERVICE OR SOURCE VOLTAGES	SIZE	NUMBER OF TERMINALS	BYPASS PROVISION	TEST SWITCH	DEMAND METERING	REACTIVE METERING
SINGLE PHASE 120/240 VOLTS (Swimming pools over 35kw will be C.T.'d or 320 amp)	Commercial	200 amp	4	BLOCK BYPASS *	NO	20KW OR GREATER NO
	Residential	200 amp	4	NO	NO	NO
		320 amp	4	BLOCK BYPASS	NO	COMMERCIAL ONLY NO
	Commercial	C.T.	6	NO	YES	20KW OR GREATER NO
	Residential	C.T.	6	NO	NO	NO
NETWORK 120/208V (2 LEGS OF Y)	Commercial	200 amp	5	SAFETY SOCKET	NO	NO
	Residential	200 amp	5	NO	NO	NO
	Commercial	C.T.	8	NO	YES	NO
4 WIRE WYE 120/208 VOLTS	200 amp	7	SAFETY SOCKET	NO	YES	NO
	C.T.	13	NO	YES	YES	YES *
4 WIRE DELTA 240/120 VOLTS	200 amp	7	SAFETY SOCKET	NO	YES	NO
	C.T.	13	NO	YES	YES	YES *
3 WIRE 3Ø DELTA 240V (Existing service only. New services, current trans. Will be 4 wire 240/120)	200 amp	5	SAFETY SOCKET	NO	YES	NO
	C.T.	8	NO	YES	YES	YES *
3 WIRE 3Ø DELTA 480V (Existing service only. New services, current trans. Will be 4 wire 240/480)	200 amp	5	SAFETY SOCKET	NO	YES	NO
	(Contact district about type of socket and whether or not current transformers and reactive metering will be required before making any 480 volt installations)					
4 WIRE 3Ø 277/480 VOLTS	200 amp B/base	7	SAFETY SOCKET	NO	YES	NO
	C.T. & V.T.	13	NO	YES	YES	YES *
	Prim. Met. 7200/120 P.T. & C.T.	13	NO	YES	YES	YES *

C.T. - Current Transformer

V.T. - Voltage Transformer

Rev 2 - Changed blocks marked with a *.

	<h2 style="margin: 0;">CONSTRUCTION STANDARDS</h2> <h3 style="margin: 0;">METERING REQUIREMENTS GENERAL</h3>			REVISIONS			
		DATE	ENGR	OPS			
	0	8/20/02			1	8/2/05	LB
2	1/13/10			CM			AH
				APP: JEH SECTION DATE: 2/22/00 900			
PAGE: 1 of 4	M			CAD FILE: M			

120/208V
1 PHASE NETWORK

SELF CONTAINED

120V 2
WIRE

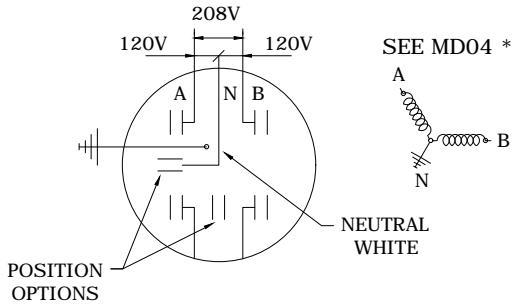

SEE MD04 *

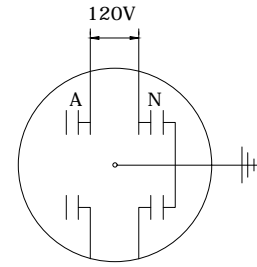

SEE MD01 *

3 PHASE
3 WIRE 240V

SINGLE PHASE
3 WIRE 120/240V

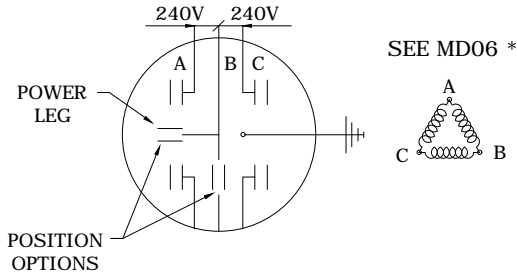

SEE MD06 *

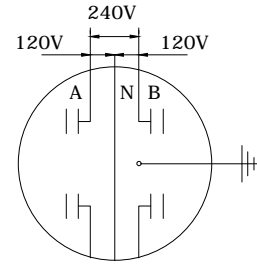

SEE MD02 *

3 PHASE 4 WIRE
DELTA 240/120V

3 PHASE 4 WIRE
WYE 120/208V
(or 277/480V)

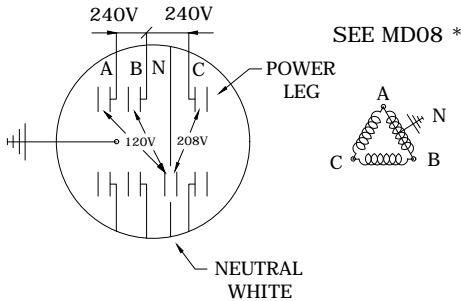

SEE MD08 *

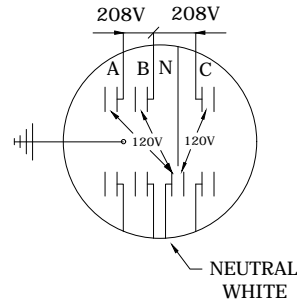

SEE MD07 *

3 WIRE SERVICE USING ONE
C.T. 6 TERMINAL SOCKET

C.T. RATED

3 WIRE SINGLE SERVICE USING 2
C.T.'s 6 TERMINAL SOCKET

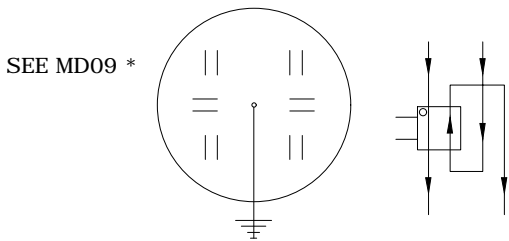

SEE MD11 *
MD11A

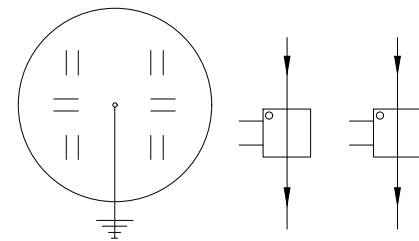

LEGEND

- CURRENT COIL
- VOLTAGE COIL

ALL METER SOCKETS TO BE GROUNDED

* REV. 1 - Added Metering Diagram Numbers.



CONSTRUCTION STANDARDS
METERING REQUIREMENTS
GENERAL

PAGE:
2 of 4

M

CAD FILE:
M

REVISIONS			
REV	DATE	ENGR	OPS
0	8/20/02		
1	8/2/05	LB	AH
REDRAWN IN CAD			
APP:	JEH	SECTION	
DATE:	2/22/00	900	

**Clark Public Utilities Metering Requirements
Commercial Applications**

Source Voltage	Ampacity	Reference Circle AW Part Number	Meter Diagram Numbers	Number of Terminals	Bypass Provision Required	Test Switch Required
120 Volts 1Ø 2 Wire	0-100 Amps	U121314*	MD01	4	Yes	No
120/240Volt 1Ø 3Wire	0-200 Amps	U264	MD02	4	Yes	No
120/240Volt 1Ø 3Wire	0-400 Amps	324N, 324NF	MD03	4	Yes	No
120/240Volt 1Ø 3Wire	Over 200 Amps	12146	MD10 MD11	6	No	Yes
240/480Volt 1Ø 3Wire	0-200 Amps	124TB	MD02 MD05 Dmd	4	Yes	No
240/480Volt 1Ø 3Wire	Over 200 Amps	12146	MD10 MD11	6	No	Yes
120/208Volt 3Wire Network	0-200 Amps	125TB	MD04	5	Yes	No
120/208Volt 3Wire Network	Over 200 Amps	12148	MD12	8	No	Yes
240Volt 3Ø 3Wire Delta	0-200 Amps	125TB	MD06	5	Yes	No
120/208Volt 3Ø 4Wire Wye	0-200 Amps	127TB	MD07	7	Yes	No
120/208Volt 3Ø 4Wire Wye	Over 200 Amps	121413	MD13	13	No	Yes
240/120Volt 3Ø 4Wire Delta	0-200 Amps	127TB	MD08	7	Yes	No
240/120Volt 3Ø 4Wire Delta	Over 200 Amps	121413	MD14	13	No	Yes
277/480Volt 3Ø 4Wire Wye	0-200 Amps	127TB	MD07	7	Yes	No
277/480Volt 3Ø 4Wire Wye	Over 200 Amps	121413	MD13	13	No	Yes
480Volt 3Ø 3Wire Delta	0-200 Amps	125TB	MD06	5	Yes	No
480Volt 3Ø 3Wire Delta	Over 200 Amps	12148	MD12	8	No	Yes

Circle AW part numbers are for cross reference only.

All Commercial current transformer cabinets shall have hinged doors.

CURRENT TRANSFORMER CABINET DIMENSIONS, CT MOUNTING BASE

Amperes	Dimensions	Circle AW or Equivalent
200 Amps- 400 Amps 1Ø	24" X 30" X 11"	6019-HAL (LUG LUG)
401 Amps- 800 Amps 1Ø	30" X 36" X 11"	6019-HEL (LUG LUG)
200 Amps- 400 Amps 3Ø	30" X 36" X 11"	6019-HAL or 6067-HAL
401 Amps- 800 Amps 3Ø	36" X 48" X 11"	6019-HEL or 6067-HEEL

See EUSERC Spec – 328B & 329B

Over 800 Amps Switchgear Required

Maximum wire size 600 MCM per lug or parallel per EUSERC SPEC. & UL label

Rev 4: Changed blocks with a *.

	<h2>CONSTRUCTION STANDARDS</h2> <p>METERING REQUIREMENTS COMMERCIAL APPLICATION</p>			REVISIONS																							
				<table border="1"> <thead> <tr> <th>△</th> <th>DATE</th> <th>ENGR</th> <th>OPS</th> </tr> </thead> <tbody> <tr> <td>1</td> <td>8/2/05</td> <td>LB</td> <td>AH</td> </tr> <tr> <td>2</td> <td>12/19/07</td> <td>LB</td> <td>AH</td> </tr> <tr> <td>3</td> <td>1/13/10</td> <td>CM</td> <td>AH</td> </tr> <tr> <td>4</td> <td>6/18/10</td> <td>KJP</td> <td></td> </tr> </tbody> </table>	△	DATE	ENGR	OPS	1	8/2/05	LB	AH	2	12/19/07	LB	AH	3	1/13/10	CM	AH	4	6/18/10	KJP				
	△	DATE	ENGR	OPS																							
	1	8/2/05	LB	AH																							
2	12/19/07	LB	AH																								
3	1/13/10	CM	AH																								
4	6/18/10	KJP																									
			<table border="1"> <thead> <tr> <th>△</th> <th>APP:</th> <th>JEH</th> <th>SECTION</th> </tr> </thead> <tbody> <tr> <td></td> <td></td> <td></td> <td align="center">900</td> </tr> </tbody> </table>	△	APP:	JEH	SECTION				900																
△	APP:	JEH	SECTION																								
			900																								
PAGE: 3 of 4	<h1>M</h1>		CAD FILE: M	APP: DATE: 2/22/00																							

Clark Public Utilities Metering Requirements
Residential Applications

Source Voltage	Ampacity	Reference Circle AW Part Number	Meter Diagram Numbers	Number of Terminals	Bypass Provision Required	Test Switch Required
120 Volts 1Ø 2 Wire	0-100 Amps	011	MD01	4	No	No
120/240 Volt 1Ø 3Wire	0-200 Amps	204, U204	MD02	4	No	No
120/240 Volt 1Ø 3Wire	0-400 Amps	324N, 324NF	MD03	4	Yes	No
120/240 Volt 1Ø 3Wire	Over 400 Amps	UO11, 011, 925 or 926	MD09 MD11A	5 or 6	No	No

Circle AW part numbers are for cross reference only.

CURRENT TRANSFORMER CABINET DIMENSIONS, CT MOUNTING BASE

Amperes	Dimensions	Circle AW or Equivalent
200 Amps- 400 Amps 1Ø Window	24"h X 32"w X 9"d	PED
*401 Amps- 800 Amps 1Ø Buss Mt.	24"h X 30"w X 11"d hinged door	6019-HAL (LUG LUG)
200 Amps- 400 Amps 3Ø Window	30"h X 36"w X 11"d	PED
*401 Amps- 800 Amps 3Ø Buss Mt.	36"h X 48"w X 11"d hinged door	6019-HEL (LUG-LUG)

* Optional

Notes: 1. CT Metering for 200- 400 Amp panels required pre-approval from Clark Public Utilities
 2. All CT cans shall be mounted outside.

Rev 2: Add optional CT cabinet dimensions and notes.



CONSTRUCTION STANDARDS
 METERING REQUIREMENTS
 RESIDENTIAL

REVISIONS			
REV	DATE	ENGR	OPS
0	8/20/02		
1	8/2/05	LB	AH
2	12/19/07	LB	AH
△ REDRAWN IN CAD			
APP:	JEH	SECTION	
DATE:	2/22/00	900	

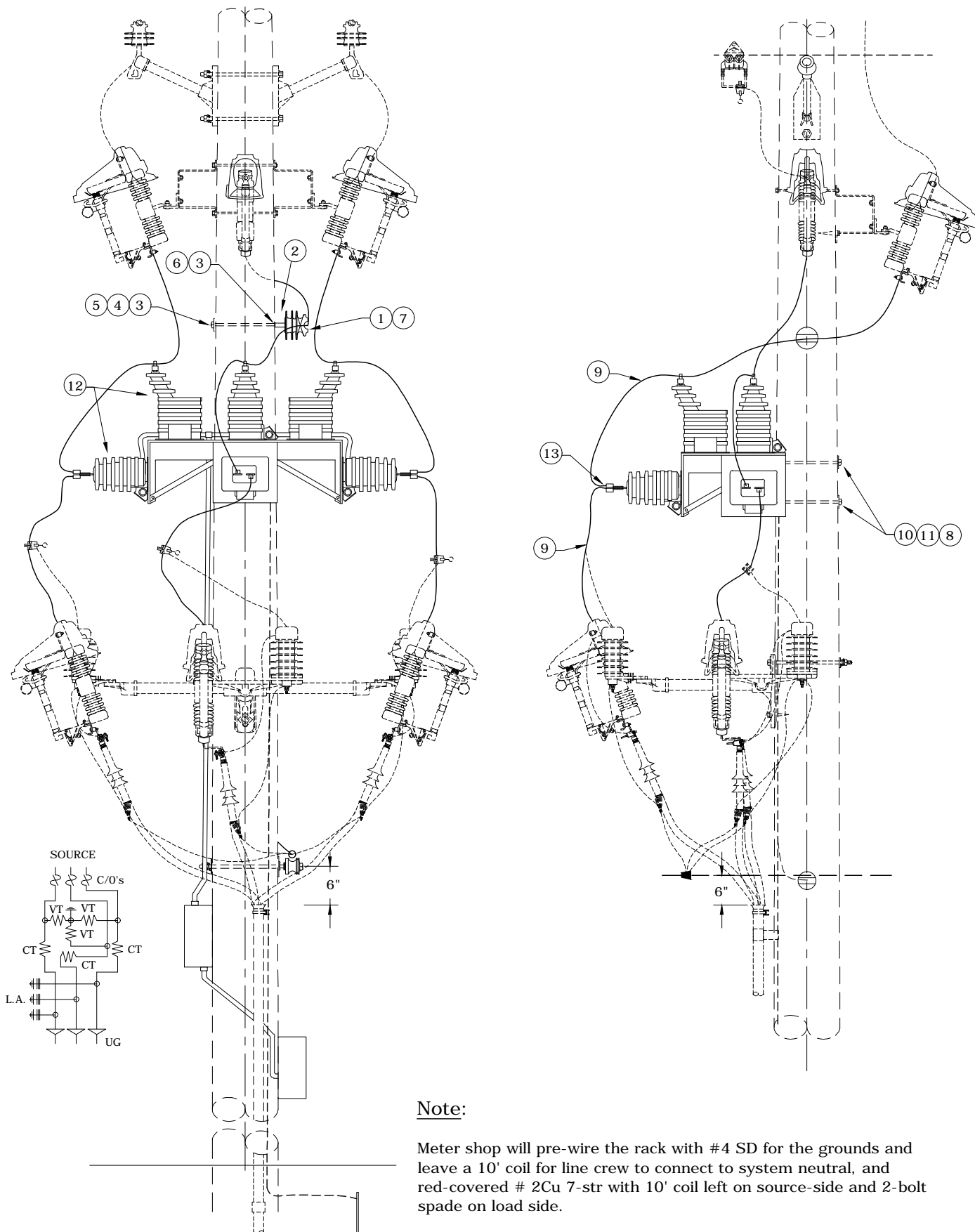

Note:
 Meter shop will pre-wire the rack with #4 SD for the grounds and leave a 10' coil for line crew to connect to system neutral, and red-covered # 2Cu 7-str with 10' coil left on source-side and 2-bolt spade on load side.

Rev 2: Changed to single-bushing PTs and updated drawing & material list.



CONSTRUCTION STANDARDS

PRIMARY METERING INSTALLATION
 OVERHEAD TO UNDERGROUND
 7.2KV, WYE - 3 ELEMENT METER

PAGE:
1 of 2

M1



CAD FILE:
M1

REVISIONS											
NO.	DATE	ENGR	OPS								
1	3/02	Redrawn	In Cad								
2	8/11/10	CM	AH								
<table border="1"> <tr> <td>APP:</td> <td>ELM</td> <td colspan="2">SECTION</td> </tr> <tr> <td>DATE:</td> <td>1/31/80</td> <td colspan="2">900</td> </tr> </table>				APP:	ELM	SECTION		DATE:	1/31/80	900	
APP:	ELM	SECTION									
DATE:	1/31/80	900									

Rev 2: Changed to single-bushing PTs and updated drawing & material list.

ITEM NO.	DESCRIPTION	PR20TREE	
		QTY.	S/N
1	Insulation Pin C Neck	1	1968
2	Pin Adapter	1	959
3	Washer, Curved, Square, Cast, 3" x 3" x 3/8" thick x 13/16" hole	2	1392
4	Bolt, Double, Arm, 5/8" x 16"	1	81
5	Washer, Lock, Spring, Double Coil, Galv., 5/8"	1	2217
6	Washer, Lock, Spring, Single Coil, Galv., 5/8"	2	1403
7	Wire, Tie, AL Annealed #4 SD	10	3012

ITEM NO.	DESCRIPTION	ADDITIONAL MATERIAL	
		QTY.	S/N
8	Bolt, Machine 5/8" x 12" Galv	2	155
9	Cond, Wire, Cu 1/C #2AWG 7Str 600V Red	60	2513
10	Washer, Curved, Square, Cast, 3" x 3" x 3/8" thick x 13/16" hole	2	1392
11	Washer, Lock, Spring, Double Coil, Galv., 5/8"	2	2217
12	MM1 from Meter Dept., CT/VT Assembly w/ Rack	1	N/S
13	Connector, Compression Lug, #2 Cu	3	427

	<h2>CONSTRUCTION STANDARDS</h2> <p>PRIMARY METERING INSTALLATION OVERHEAD TO UNDERGROUND 7.2KV, WYE - 3 ELEMENT METER</p>		REVISIONS			
		DATE	ENGR	OPS		
	1	3/02	Redrawn	In Cad		
	2	8/11/10	CM	AH		
PAGE: 2 of 2		M1	CAD FILE: M1		APP: ELM DATE: 1/31/80	
				SECTION 900		

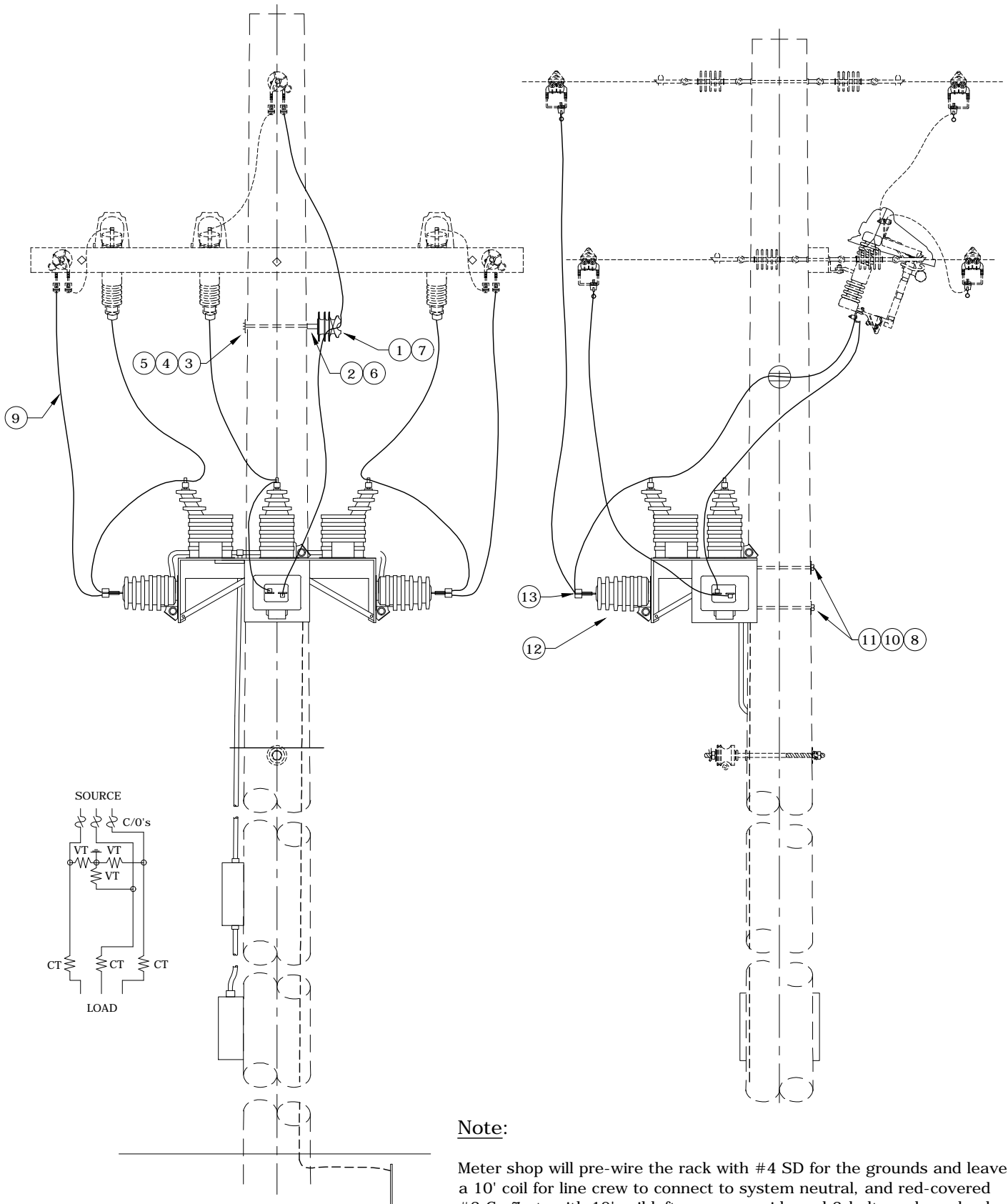

Note:

Meter shop will pre-wire the rack with #4 SD for the grounds and leave a 10' coil for line crew to connect to system neutral, and red-covered #2 Cu 7-str with 10' coil left on source-side and 2-bolt spade on load side.

Rev 2: Changed to single-bushing PTs, removed arresters, and updated drawing & material list.



CONSTRUCTION STANDARDS
 PRIMARY METERING INSTALLATION
 OVERHEAD CONSTRUCTION
 7.2KV, WYE - 3 ELEMENT METER

PAGE:
1 of 2

M1A

CAD FILE:
M1A

REVISIONS			
NO.	DATE	ENGR	OPS
1	3/02	Redrawn	In Cad
2	8/11/10	CM	AH
APP: ELM		SECTION	
DATE: 1/31/80		900	

Rev 2: Changed to single-bushing PTs, removed arresters, and updated drawing & material list.

ITEM NO.	DESCRIPTION	PR20TREE	
		QTY.	S/N
1	Insulation Pin C Neck	1	1968
2	Pin, Adapter	1	959
3	Washer, Curved, Square, Cast, 3" x 3" x 3/8" thick x 13/16" hole	2	1392
4	Bolt, Double Arm, 5/8" x 16"	1	81
5	Washer, Lock, Spring, Double Coil, Galv., 5/8"	1	2217
6	Washer, Lock, Spring, Single Coil, Galv., 5/8"	2	1403
7	Wire, Tie, AL Annealed #4 SD	10	3012

ITEM NO.	DESCRIPTION	Additional Material	
		QTY.	S/N
8	Bolt, Machine 5/8" x 12" Galv	2	155
9	Cond, Wire, Cu 1/C #2AWG 7Str 600V Red	60	2513
10	Washer, Curved, Square, Cast, 3" x 3" x 3/8" thick x 13/16" hole	2	1392
11	Washer, Lock, Spring, Double Coil, Galv., 5/8"	2	2217
12	MM1A from Meter Dept., CT/VT Assembly w/ Rack	1	N/S
13	Connector, Compression Lug, #2 Cu	3	427

	CONSTRUCTION STANDARDS			REVISIONS			
	PRIMARY METERING INSTALLATION OVERHEAD CONSTRUCTION 7.2KV, WYE - 3 ELEMENT METER			DATE	ENGR	OPS	
	1	3/02	Redrawn	In Cad			
	2	8/11/10	CM	AH			
PAGE: 2 of 2			M1A			CAD FILE: M1A	
			APP: ELM		SECTION		
			DATE: 1/31/80		900		

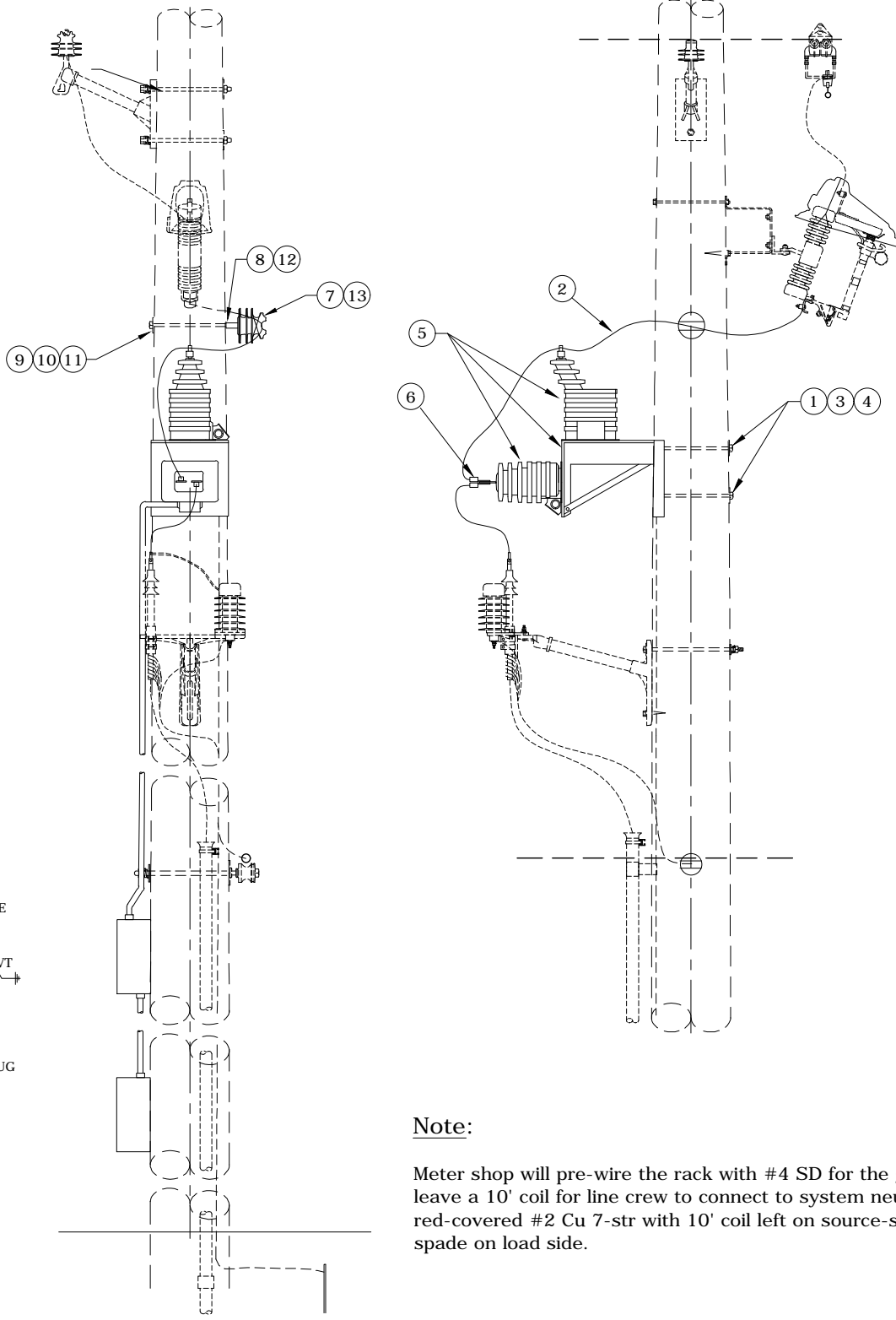

Note:

Meter shop will pre-wire the rack with #4 SD for the grounds and leave a 10' coil for line crew to connect to system neutral, and red-covered #2 Cu 7-str with 10' coil left on source-side and 2-bolt spade on load side.

Rev 2: Changed to single-bushing PTs and drawing & material corrections.



CONSTRUCTION STANDARDS

PRIMARY METERING INSTALLATION
OVERHEAD TO UNDERGROUND
7.2KV, 1 PHASE, 1 ELEMENT METER

PAGE:
1 of 2

M4



CAD FILE:
M4

REVISIONS			
NO.	DATE	ENGR	OPS
1	3/02	Redrawn	In Cad
2	8/11/10	CM	AH
APP: ELM		SECTION	
DATE: 1/31/80		900	

Rev 2: Changed to single-bushing PTs and drawing & material corrections.

ITEM NO.	DESCRIPTION	ADDITIONAL MATERIAL	
		QTY.	S/N
1	Bolt, Machine 5/8" x 12" Galv	2	155
2	Cond, Wire, Cu 1/C #2 7Str 600V Red	20	2513
3	Washer, Curved, Square, Cast, 3" x 3" x 3/8" thick x 13/16" hole	2	1392
4	Washer, Lock, Spring, Double Coil, Galv., 5/8"	2	2217
5	MM1 from Meter Dept., CT/VT Assembly w/ Rack	1	N/S
6	Connector, Compression Lug, #2 Cu	1	427

ITEM NO.	DESCRIPTION	PR20TREE	
		QTY.	S/N
7	Insulation Pin C Neck	1	1968
8	Pin Adapter	1	959
9	Washer, Curved, Square, Cast, 3" x 3" x 3/8" thick x 13/16" hole	2	1392
10	Bolt, Double, Arm, 5/8" x 16"	1	81
11	Washer, Lock, Spring, Double Coil, Galv., 5/8"	1	2217
12	Washer, Lock, Spring, Single Coil, Galv., 5/8"	2	1403
13	Wire, Tie, AL Annealed #4 SD	10	3012

	CONSTRUCTION STANDARDS PRIMARY METERING INSTALLATION OVERHEAD TO UNDERGROUND 7.2KV, 1 PHASE, 1 ELEMENT METER		REVISIONS			
		DATE	ENGR	OPS		
	1	3/02	Redrawn	In Cad		
	2	8/11/10	CM	AH		
PAGE: 2 of 2		M4	CAD FILE: M4		APP: ELM DATE: 1/31/80	SECTION 900

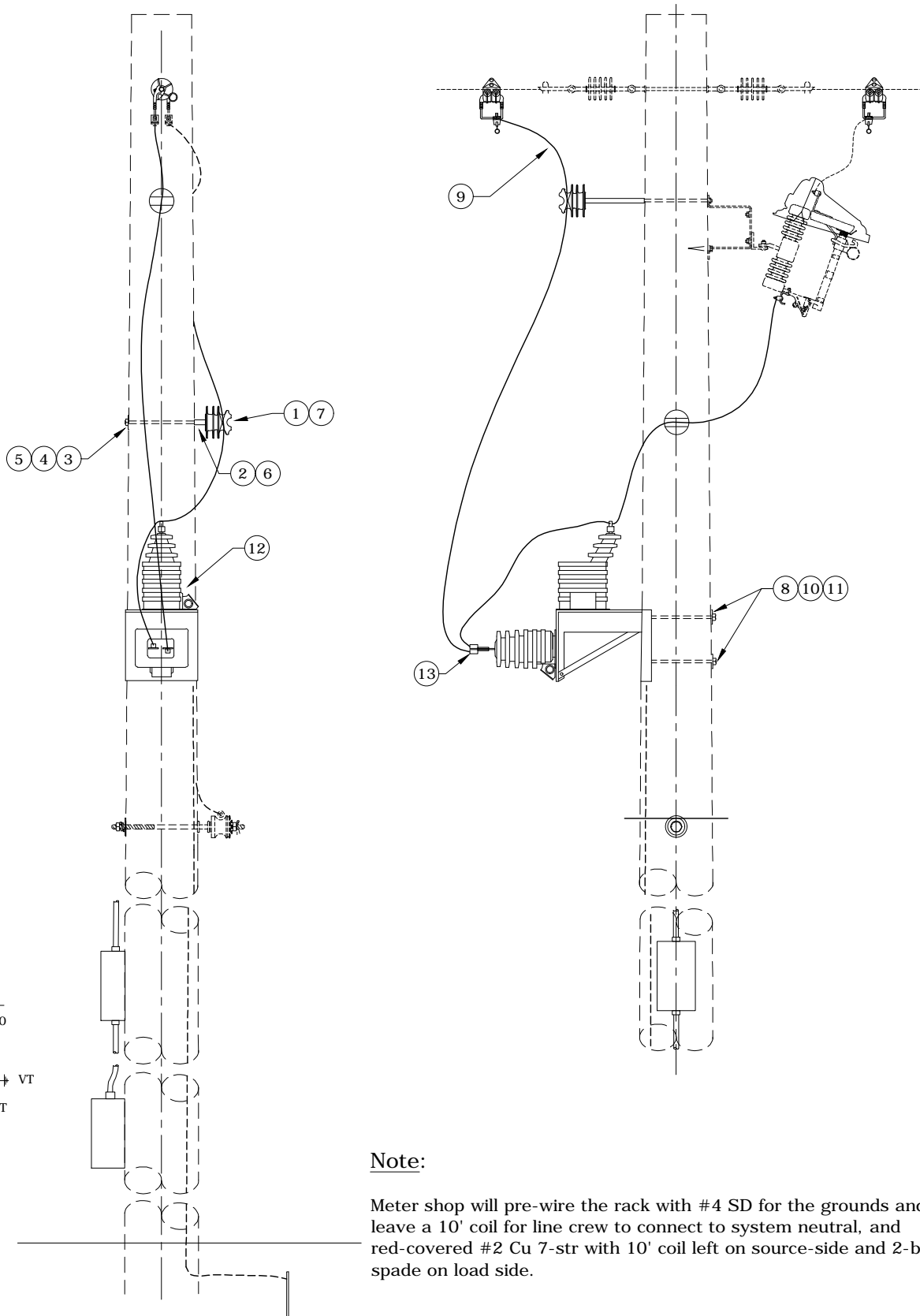

Note:

Meter shop will pre-wire the rack with #4 SD for the grounds and leave a 10' coil for line crew to connect to system neutral, and red-covered #2 Cu 7-str with 10' coil left on source-side and 2-bolt spade on load side.

Rev 2: Changed to single-bushing PTs, removed lightning arrester and drawing & material corrections.



CONSTRUCTION STANDARDS

PRIMARY METERING INSTALLATION
OVERHEAD CONSTRUCTION
7.2KV, 1 PHASE, 1 ELEMENT METER

REVISIONS			
NO.	DATE	ENGR	OPS
1	3/02	Redrawn	In Cad
2	8/11/10	CM	AH

PAGE:	CAD FILE:	APP:	ELM	SECTION
1 of 2	M4A	DATE:	1/31/80	900

Rev 2: Changed to single-bushing PTs, removed lightning arrester and drawing & material corrections.

ITEM NO.	DESCRIPTION	PR20TREE	
		QTY.	S/N
1	Insulation Pin C Neck	1	1968
2	Pin, Adapter	1	959
3	Washer, Curved, Square, Cast, 3" x 3" x 3/8" thick x 13/16" hole	2	1392
4	Bolt, Double Arm, 5/8" x 16"	1	81
5	Washer, Lock, Spring, Double Coil, Galv., 5/8"	1	2217
6	Washer, Lock, Spring, Single Coil, Galv., 5/8"	2	1403
7	Wire, Tie, AL Annealed #4 SD	10	3012

ITEM NO.	DESCRIPTION	Additional Material	
		QTY.	S/N
8	Bolt, Machine 5/8" x 12" Galv	2	155
9	Cond, Wire, Cu 1/C #2AWG 7Str 600V Red	20	2513
10	Washer, Curved, Square, Cast, 3" x 3" x 3/8" thick x 13/16" hole	2	1392
11	Washer, Lock, Spring, Double Coil, Galv., 5/8"	2	2217
12	MM1A from Meter Dept., CT/VT Assembly w/ Rack	1	N/S
13	Connector, Compression Lug, #2 Cu	1	427

	CONSTRUCTION STANDARDS PRIMARY METERING INSTALLATION OVERHEAD CONSTRUCTION 7.2KV, 1 PHASE, 1 ELEMENT METER		REVISIONS				
			△	DATE	ENGR	OPS	
			1	3/02	Redrawn	In Cad	
			2	8/11/10	CM	AH	
PAGE: 2 of 2		M4A	CAD FILE: M4A		APP: ELM DATE: 1/31/80	SECTION 900	

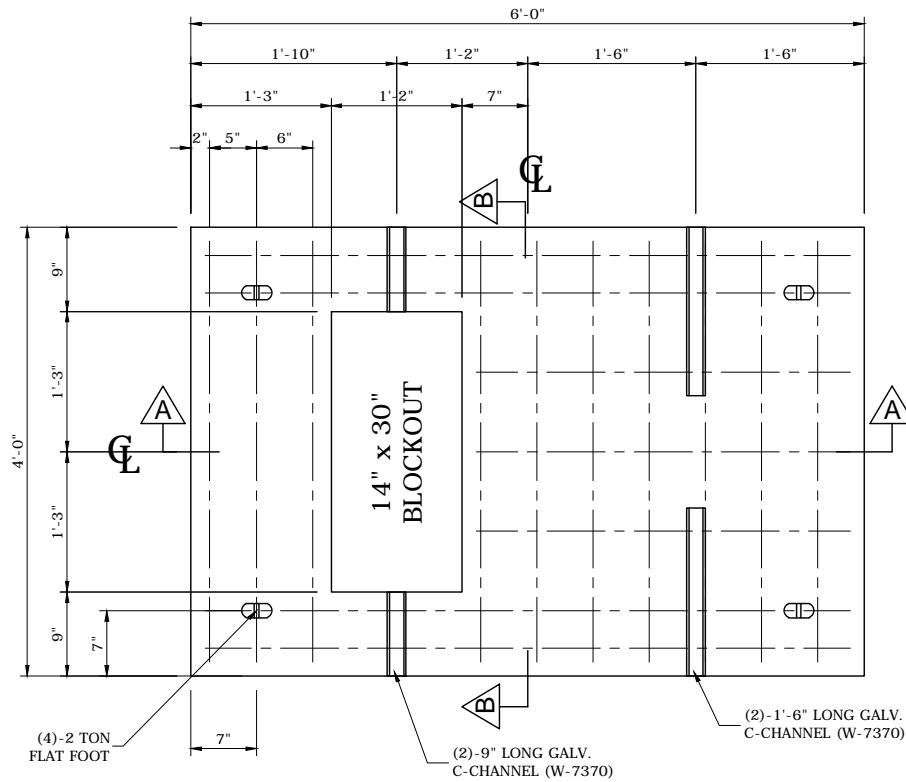

PLAN

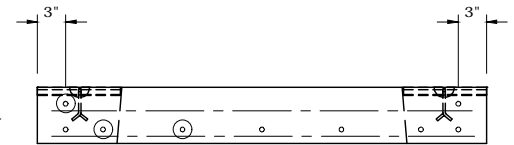

SECTION "B-B"

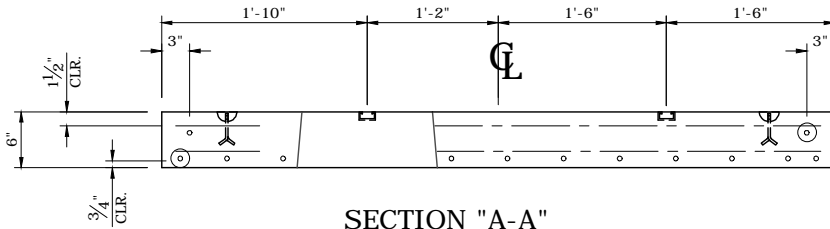

SECTION "A-A"

CONCRETE:
VOL. = VOLUME
WT. = WEIGHT

BILL OF MATERIAL				
PART	DESCRIPTION	QTY.	SIZE	TOTAL WT. LBS.
1	#6 GR. 60	9	6'-9"x STR.	91
2	#6 GR. 60	2	6'-9"x STR.	20
2A	#6 GR. 60	5	4'-11"x STR.	37
3	#4 GR. 60	2	6'-9"x STR. TOP	9
4	#4 GR. 60	2	6'-9"x STR. TOP	9
	LIFT ANCHOR	4	2 TON SPREAD	
	C-CHANNEL(W-7370)	2	8" LONG	
	C-CHANNEL(W-7370)	2	1'-6" LONG	

CONCRETE PAD DETAILS FOR 1Ø 200 AMP
UNDERGROUND PRIMARY METERING ENCLOSURE

1. ALL CONCRETE SHALL BE 2500 PSI AND HAVE A SLUMP OF 4" TO 6".
2. REINFORCING SHALL CONFORM TO ASTM DESIGNATION A15 AND A305.
3. TROWEL SMOOTH SURFACES AND BRUSH FINISH. ROUND ALL EDGES.

GENERAL NOTES:

1. UTILITY VAULT PAD #4872SLB6-1430CLARK

Rev 4: New pad dimensions for 200 amp 1Ø underground metering enclosure



CONSTRUCTION STANDARDS
UNDERGROUND PRIMARY METERING PAD
SINGLE PHASE
200 AMP

PAGE:
1 of 1

M7

CAD FILE:
M7

REVISIONS			
NO.	DATE	ENGR	OPS
1	3/02	REDRAWN	IN CAD
2	7/15/02	JEH	TR
3	8/2/05	LB	AH
4	12/19/07	LB	AH

APP:	ELM	SECTION
DATE:	1/31/80	900

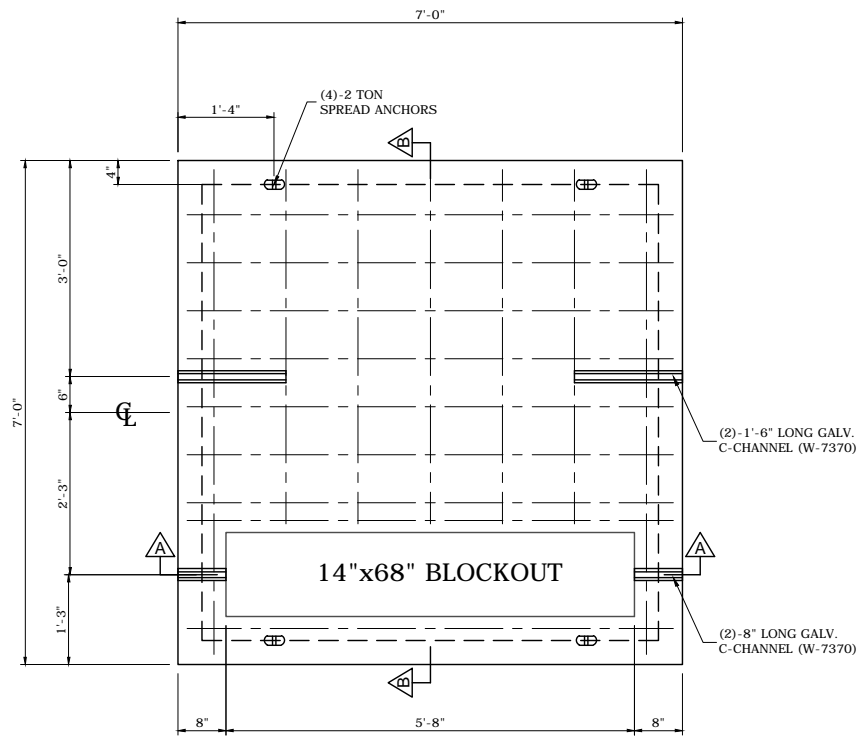

PLAN

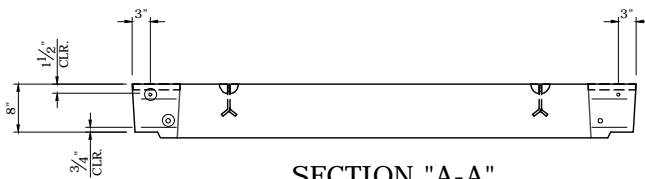

SECTION "A-A"

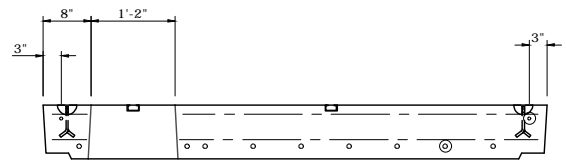

SECTION "B-B"

CONCRETE:
VOL. = 1.1775 CU YD
WT. = 4,769 LB

BILL OF MATERIAL				
PART	DESCRIPTION	QTY.	SIZE	TOTAL WT. LBS.
1	#6 GR. 60	9	6'-9" x STR.	91
2	#6 GR. 60	2	6'-9" x STR.	20
2A	#6 GR. 60	5	4'-11" x STR.	37
3	#4 GR. 60	2	6'-9" x STR. TOP	9
4	#4 GR. 60	2	6'-9" x STR. TOP	9
	LIFT ANCHOR	4	2 TON SPREAD	
	C-CHANNEL(W-7370)	2	8" LONG	
	C-CHANNEL(W-7370)	2	1'-6" LONG	

CONCRETE PAD DETAILS FOR 3Ø 200 AMP UNDERGROUND PRIMARY METERING ENCLOSURE

1. ALL CONCRETE SHALL BE 2500 PSI AND HAVE A SLUMP OF 4" TO 6".
2. REINFORCING SHALL CONFORM TO ASTM DESIGNATION A15 AND A305.
3. TROWEL SMOOTH SURFACES AND BRUSH FINISH. ROUND ALL EDGES.

GENERAL NOTES:

1. UTILITY VAULT PAD 77T8-1468-CLARK
2. VAULT PAD TO BE PLACED ON UTILITY VAULT #774
3. S/N 2332 IS FOR VAULT AND COVER

Rev 1: Added note# 3

	<p align="center">CONSTRUCTION STANDARDS</p> <p align="center">UNDERGROUND PRIMARY METERING PAD THREE PHASE 200 AND 600 AMP</p>		<p align="center">REVISIONS</p>																			
			<table border="1"> <thead> <tr> <th>DATE</th> <th>ENGR</th> <th>OPS</th> </tr> </thead> <tbody> <tr> <td>6/18/10</td> <td>KJP</td> <td></td> </tr> <tr> <td></td> <td></td> <td></td> </tr> <tr> <td></td> <td></td> <td></td> </tr> </tbody> </table>	DATE	ENGR	OPS	6/18/10	KJP								<p>PAGE: 1 of 1</p>	<p align="center">M8</p>	<p>CAD FILE: xM8</p>	<table border="1"> <thead> <tr> <th>APP:</th> <th>LB/AH</th> <th>SECTION</th> </tr> </thead> <tbody> <tr> <td>DATE: 12/19/07</td> <td></td> <td align="center">900</td> </tr> </tbody> </table>	APP:	LB/AH	SECTION
DATE	ENGR	OPS																				
6/18/10	KJP																					
APP:	LB/AH	SECTION																				
DATE: 12/19/07		900																				

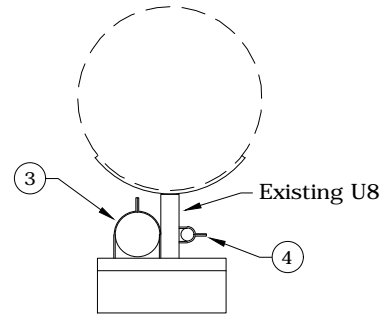
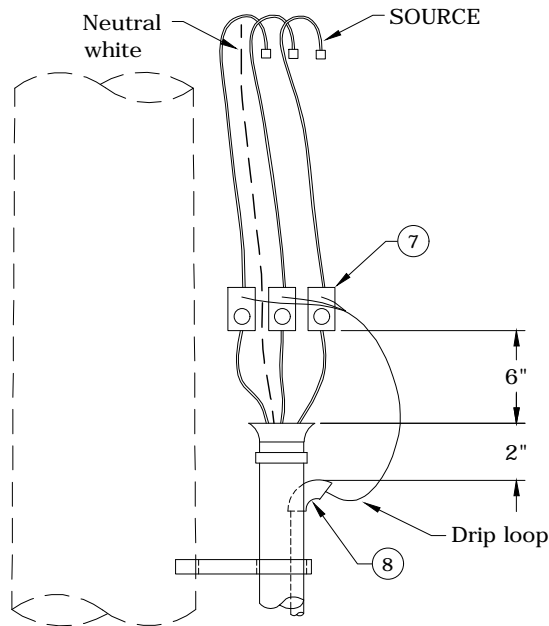

SECTION AA

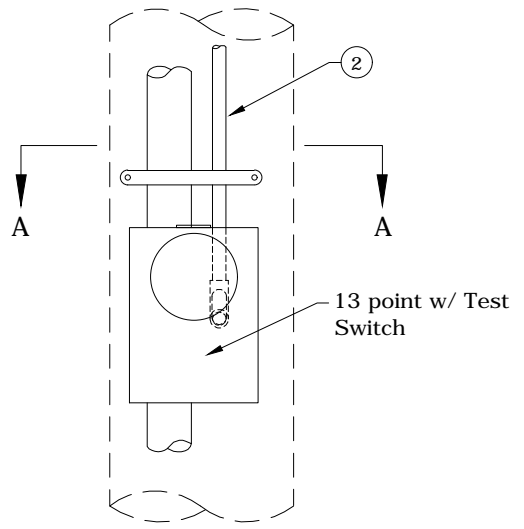
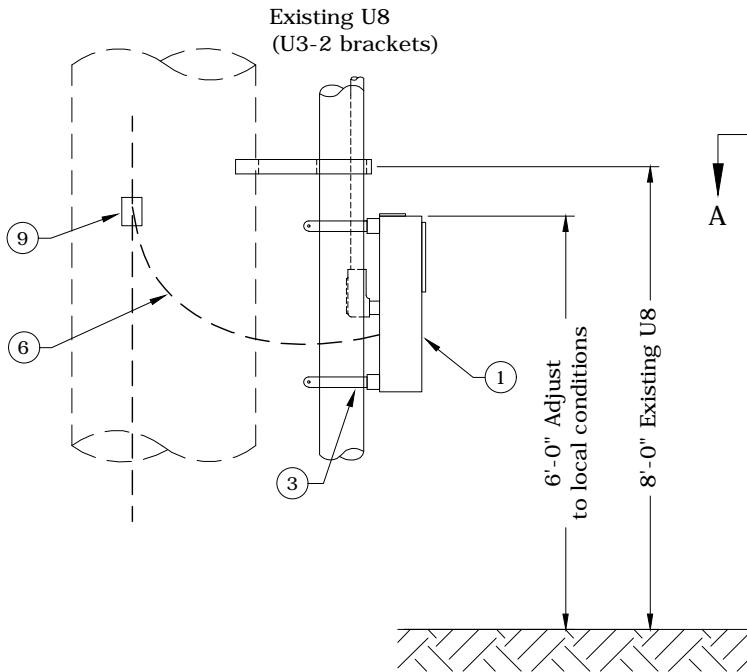

R2 - Minor drawing changes

ITEM NO.	DESCRIPTION	M16	
		QTY.	S/N
1	Meter base, Superior, w/ channel 1 1/2" x 1 1/2", from Meter Dept.	1	MM1
2	LB, from Meter Dept.	1	MM1
3	Strap, Pipe 3" HW	2	1243
4	Strap, Pipe 1" HW	2	1239
5	Conduit, Schedule 80 PVC 1" x 10'	20	2482
6	Conductor, BSDC 4SLD 1C	10	376
7	Transformer, current, from Meter Dept.	3	MM1
8	Weatherhead 1", from Meter Dept.	1	MM1
9	Connector, crimpet Cu 4/4 - 6/6	1	452



CONSTRUCTION STANDARDS
 SECONDARY METERING INSTALLATION
 POLE MOUNTED - 3 PHASE, 4 WIRE

REVISIONS			
DATE	ENGR	OPS	
3/02	Redrawn	In Cad	1
7/15/02	JEH	TR	2

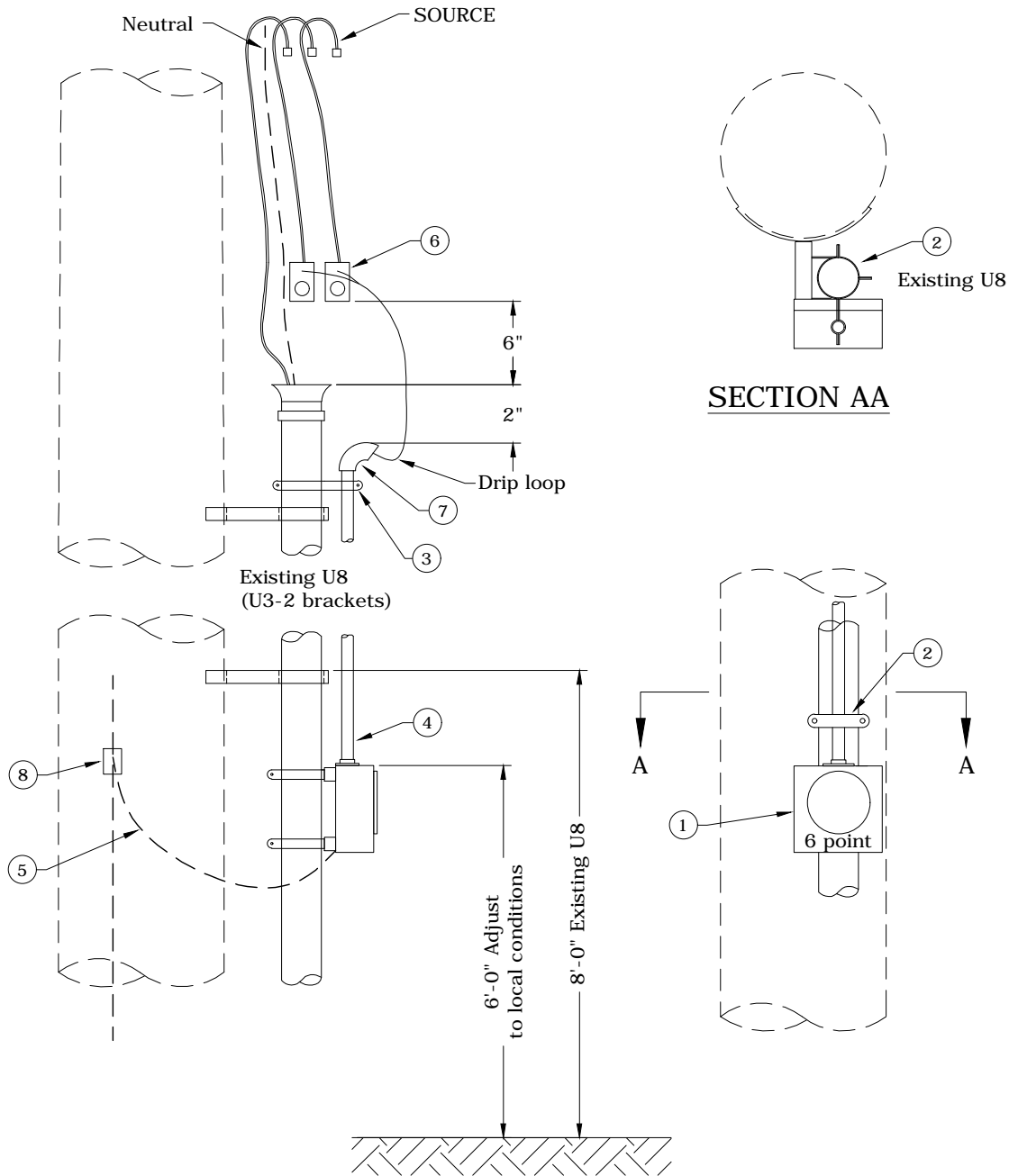

R2 - Minor drawing changes

ITEM NO.	DESCRIPTION	M17	
		QTY.	S/N
1	Meter base w/ channel 3/4" x 1 1/2" from Meter Dept.	1	MM1
2	Strap, Pipe 3" HW	2	1243
3	Conduit band from Meter Dept.	2	MM1
4	Conduit, Schedule 80 PVC 3/4" x 10'	20	2221
5	Conductor, BSDC 4SLD 1C	10	376
6	Transformer, current, from Meter Dept.	2	MM1
7	Weatherhead 3/4", from Meter Dept.	1	MM1
8	Connector, crimpet, Cu 4/4 - 6/6	1	452



CONSTRUCTION STANDARDS
SECONDARY METERING INSTALLATION
POLE MOUNTED - 1 PHASE, 3 WIRE

REVISIONS			
DATE	ENGR	OPS	
3/02	Redrawn	In Cad	
7/15/02	JEH	TR	

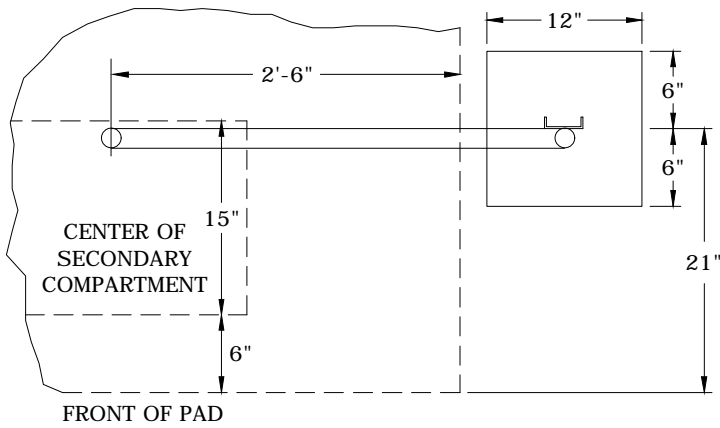

PLAN VIEW
TRANSFORMER PAD & METER FOOTING

Notes:

1. CIRCLE AW 121413 OR EQUIVALENT. METER BASE, 13 POINT, W/SPACE FOR TEST SWITCH.
2. CT's WILL BE FURNISHED BY CPU. *
3. CUSTOMER WILL INSTALL ASSEMBLY WHEN TRANSFORMER & PAD ARE INSTALLED.
4. CUSTOMER TO POUR CONCRETE FOOTING FOR METER.
5. MAY BE REDUCED TO 4' PROVIDED NOT LESS THAN FLUSH WITH TOP OF TRANSFORMER.
6. THIS INSTALLATION SHALL BE USED ONLY WHEN IT IS IMPRACTICAL TO INSTALL THE METER ON THE BUILDING AND ONLY AFTER DISTRICT APPROVAL.

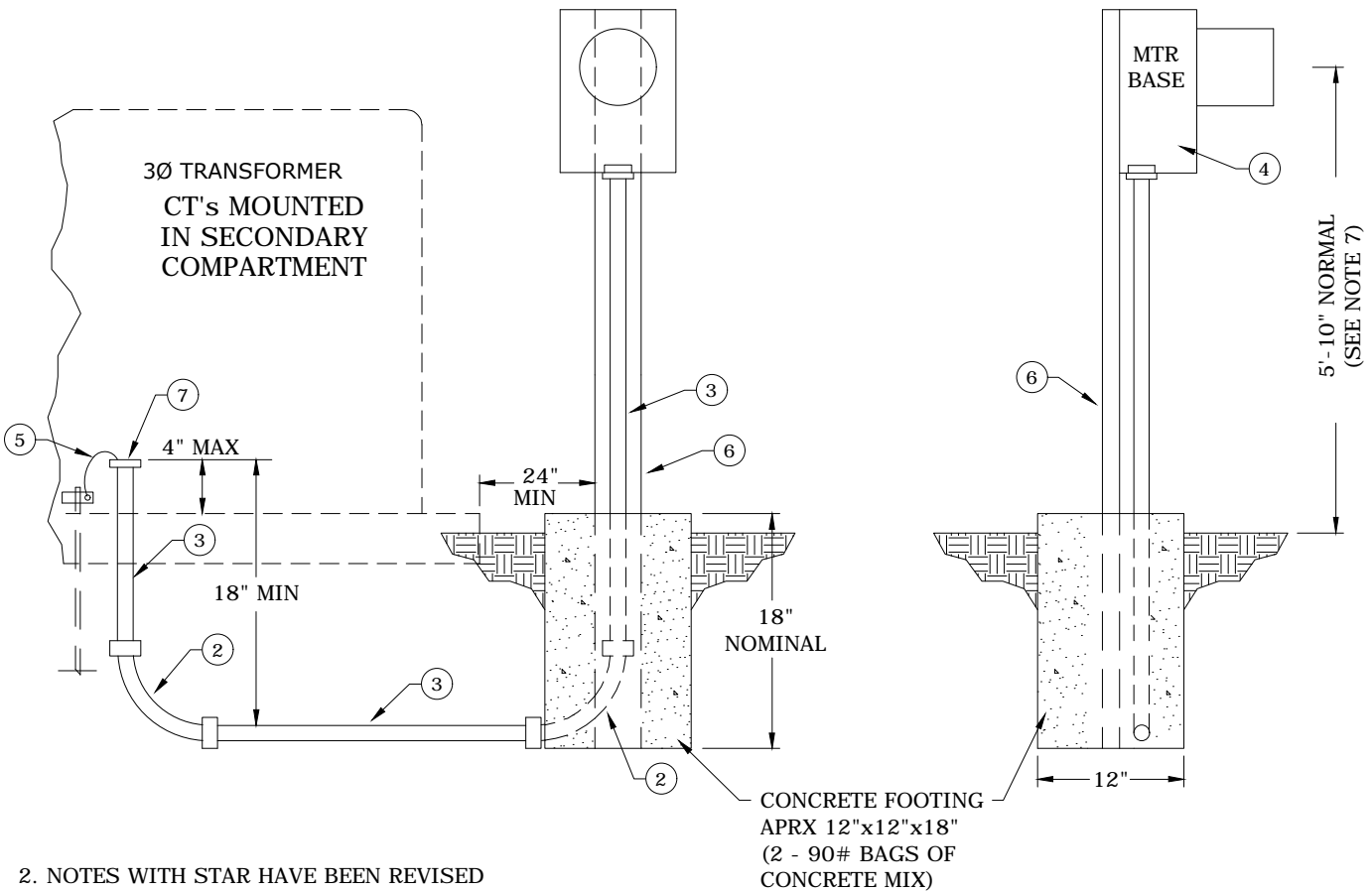

2. NOTES WITH STAR HAVE BEEN REVISED
1. REMOVED CT CAN

ITEM NO.	DESCRIPTION	M20	
		QTY.	S/N
1	Locknut 1"	3	---
2	Ell-90° Cond. 1" Rigid or Sch. 80 PVC	2	---
3	Conduit 1" Rigid or Sch. 80 PVC	Ft.	---
4	Meter Base W/ Test Block - See Note 1	1	---
5	Ground Wire #6 Cu	Ft.	---
6	Channel Support 3" x 8" x 3/8", 5'6"	1	---
7	Bushing Conduit Grounding	4	---



CONSTRUCTION STANDARDS
PAD & ASSEMBLY
SECONDARY METERING
FOR PADMOUNT TRANSFORMER

PAGE:
1 of 1

M20

CAD FILE:
M20

REVISIONS			
DATE	ENGR	OPS	
2/22/00	HWH	MA	
8/1/00			

APP:
DATE: 1/31/80

SECTION
900

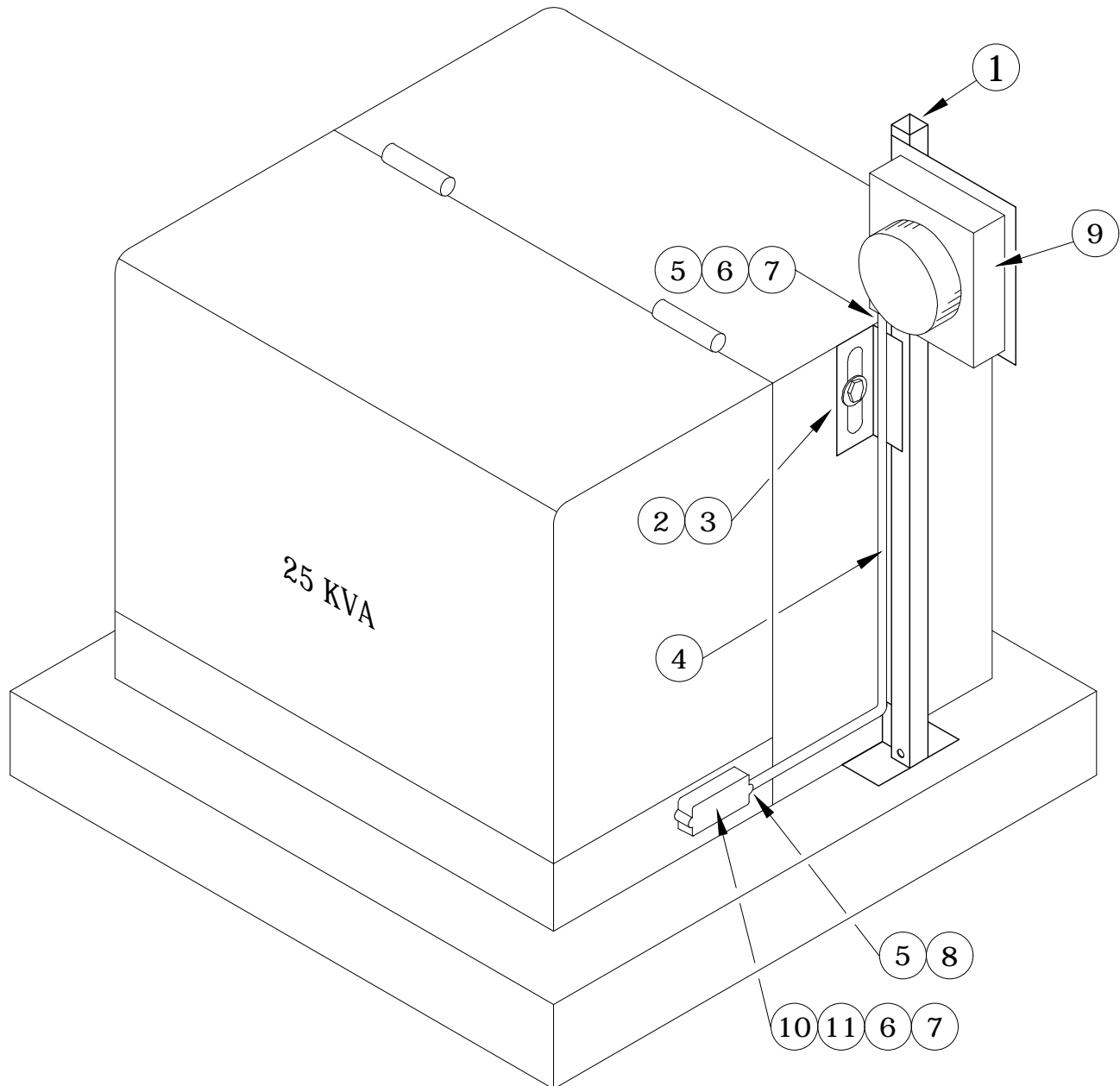

* M.D.S. MEANS METER DEPARTMENT STOCK

ITEM NO.	DESCRIPTION	M23	
		QTY.	S/N
1	CT METER BASE SUPPORT DRAWING MBCT	1	M.D.S. *
2	MACHINE BOLT 5/8" X 1"	1	138
3	WASHER, FLAT, ROUND, GALV, 5/8"	1	1395
4	CONDUIT, PVC, SCH. 40, 3/4"	43"	1564
5	ADAPTER, PVC, MALE, 3/4"	1	M.D.S. *
6	BUSHING, INSULATED, 3/4"	1	2027
7	LOCKNUT, 3/4"	2	M.D.S. *
8	CONDULET, L.B., 3/4"	10'	M.D.S. *
9	METER BASE, 6, TERMINAL	1	M.D.S. *
10	REDUCER, 3/4" X 2"	1	M.D.S. *
11	NIPPLE, 3/4", CLOSE	1	M.D.S. *



CONSTRUCTION STANDARDS

DISTRICT INSTALLED
CT METERING AT PADMOUNT
TRANSFORMER

REVISIONS

REV	DATE	ENGR	OPS
1	2/23/00	HWH	MA

PAGE:
1 of 1

M23

CAD FILE:
M23

APP:
DATE: 4/92

SECTION
900

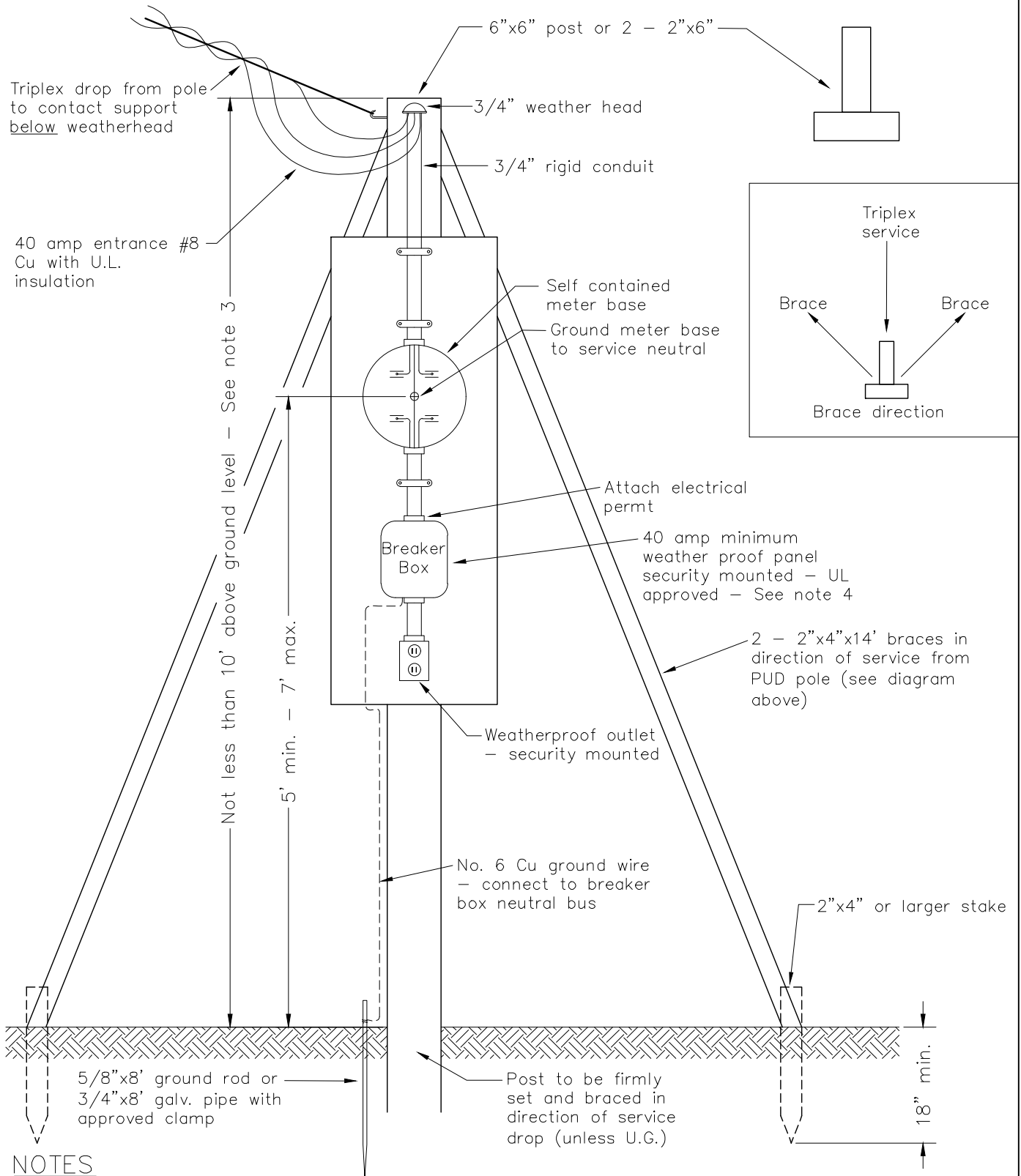

NOTES

1. Install service and support 3' from pedestal for U.G. service.
2. Ground equipment per state and local code requirements.
3. Service must clear driveways 12' and streets 18'.
4. Panel circuit breakers must have 10,000 amp interrupting rating.
5. DO NOT attach to district poles.

This installation must be inspected by the Dept. of Labor & Industries before Clark Public Utility can energize.

Dept. of Labor & Industries, 896-2350
City of Vancouver, 696-8105



CONSTRUCTION STANDARDS
LAYOUT FOR TEMPORARY ELECTRICAL SERVICE
120/240V - 3 WIRE

PAGE:
1 of 1

M28

CAD FILE:
M28

REVISIONS			
DATE	ENGR	OPS	
3/02			
Redrawn In Cad			
APP:	SECTION		
DATE: 1965	900		

TRIPOD DETAIL

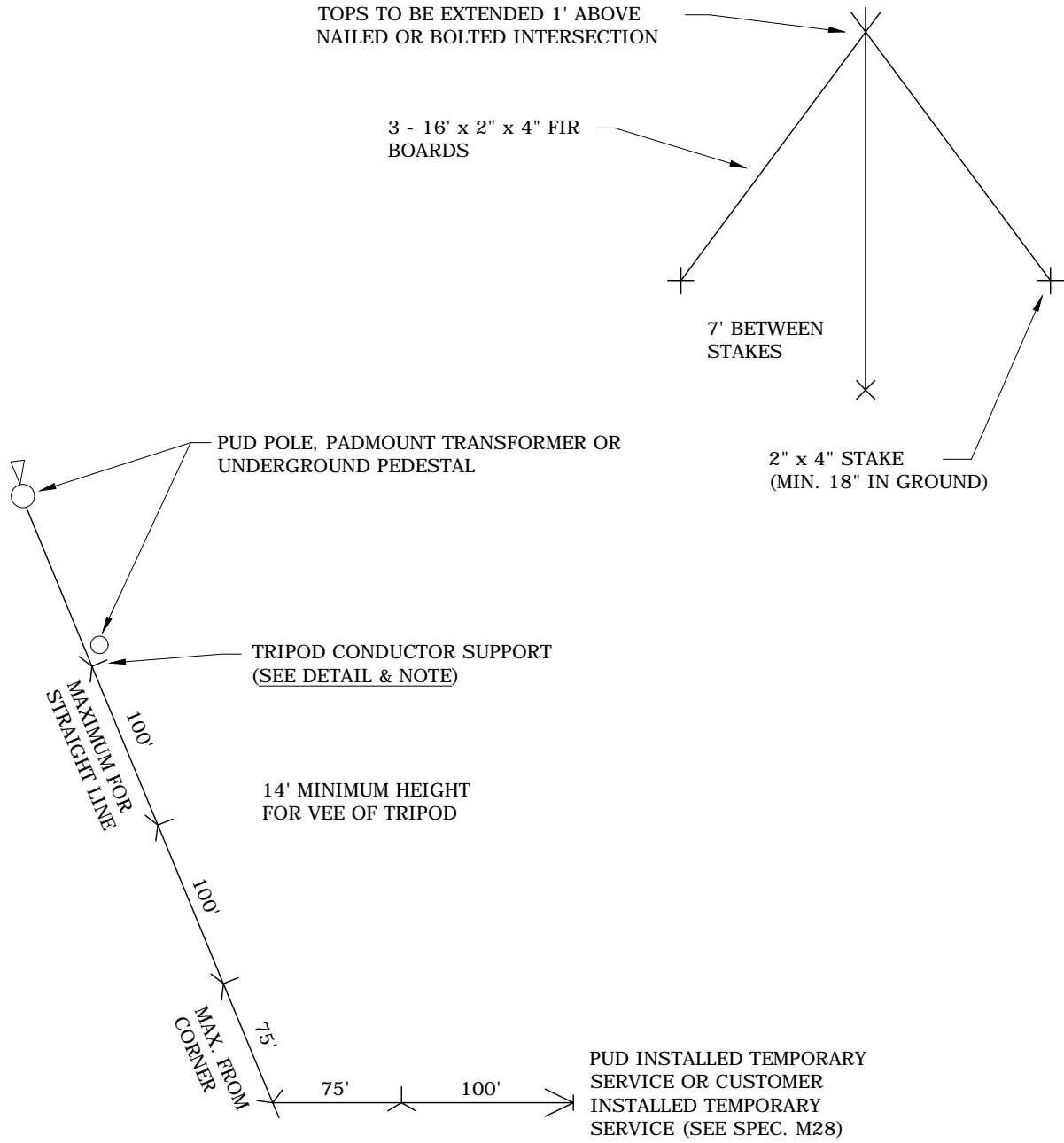

Note: IF SERVICE CROSSES A ROADWAY, USE 24' x 2" x 6" FIR BOARDS FOR TRIPODS & PLACE ADJACENT TO ROADWAY TO REDUCE CONDUCTOR SPAN & PROVIDE MINIMUM OF 18' CLEARANCE (CHECK WITH PUD ENGINEER IF SERVICE ROUTE CROSSES STATE HIGHWAY).

TO BE USED ONLY WITH DISTRICT APPROVAL



CONSTRUCTION STANDARDS
 CONDUCTOR SUPPORTS
 FOR TEMPORARY ELECTRIC SERVICE

REVISIONS			
NO.	DATE	ENGR	OPS
1	3/02		
⚠ Redrawn In Cad			
APP:		SECTION	
DATE: 8/76		900	

PAGE:
1 of 1

M28A

CAD FILE:
M28A

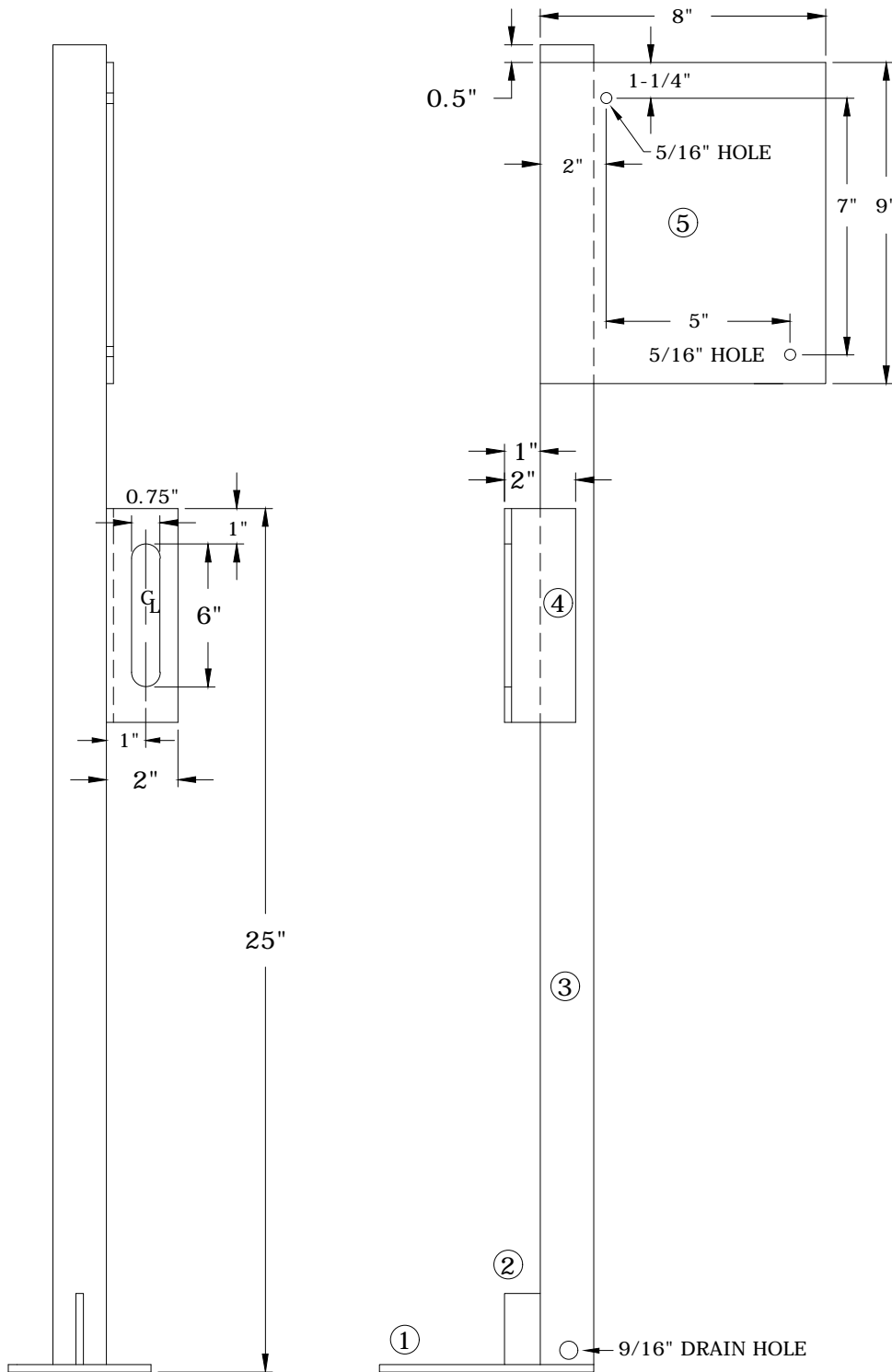

NOTE: HOT DIP GALVANIZE AFTER FABRICATION

ITEM NO.	DESCRIPTION	MBCT	
		QTY.	S/N
1	Plate, Steel Base, 4" x 6" x 1/8"	-	--
2	Plate, Steel Spacer, 1" x 2" x 1/8"	-	--
3	Tube, 1/8" Square, 1 1/2" x 36"	-	--
4	Angle Steel, 1/8" Thick, 2" x 2" x 8"	-	--
5	Plate, Steel, 8" x 9" x 1/8"	-	--



CONSTRUCTION STANDARDS
 CT METER BASE SUPPORT FOR
 PADMOUNT TRANSFORMER

REVISIONS			
NO.	DATE	ENGR	OPS
1	2/23/00	HWH	MA

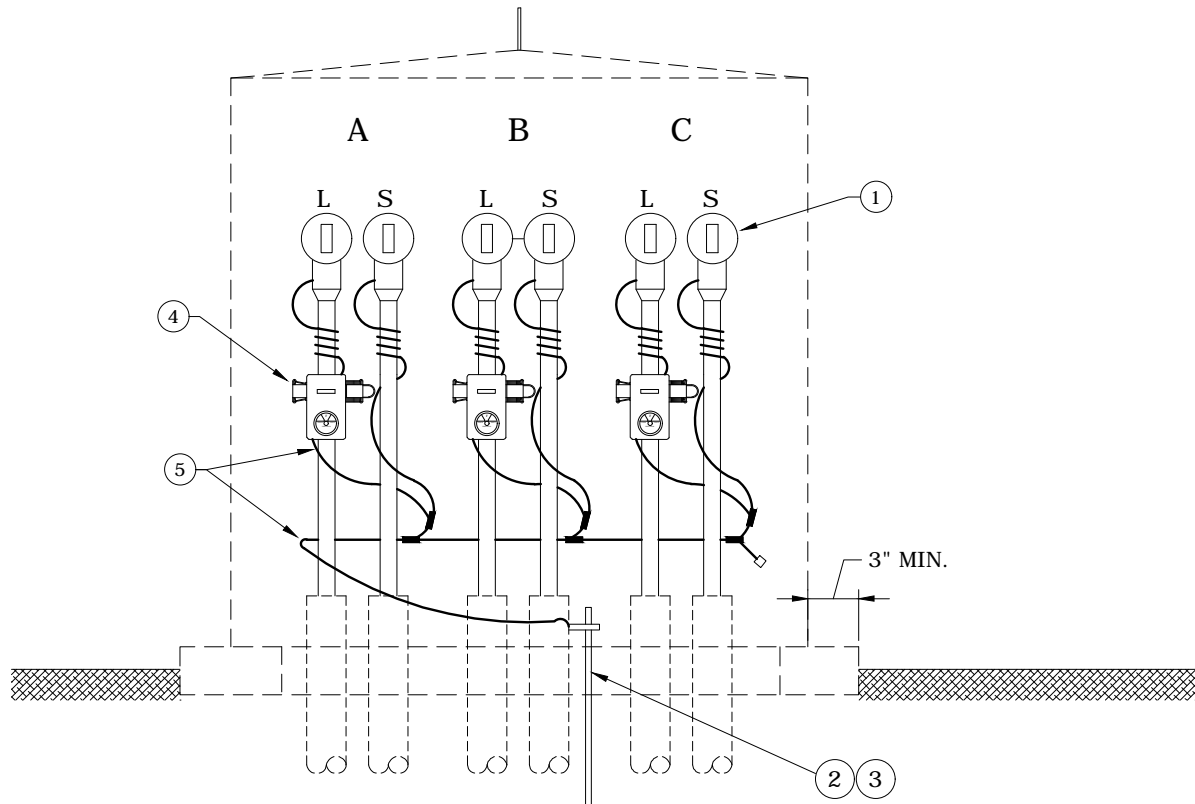

ELEVATION
FRONT VIEW

ALL NEUTRAL EXTENSIONS SHALL BE #2 B.C.

NOTE: PRIMARY METER ENCLOSURE IS NOT A STOCK ITEM. FOR A REPLACEMENT FOR CPU MAINTENANCE, A "PURCHASE REQUISITION" MUST BE GENERATED BY THE ENGINEER FOR PURCHASING. PURCHASING WILL GENERATE THE "PURCHASE ORDER." A COPY OF THE SPECIFICATION FOR THE ENCLOSURE IS IN THE METERING MANUAL.

REV 2: CHANGED TO CURRENT-RESET FAULT INDICATORS & ADDED NOTES

ITEM NO.	DESCRIPTION	UM1	
		QTY.	S/N
1	Terminator, Elbow L.B. 200A	6	1312
2	Clamp, Ground Rod 5/8" SML	1	281
3	Clamp, Ground Rod 5/8" x 8'	1	1124
4	Fault Indicator	3	2581 *
5	Conductor, Copper, #2 Sol. BCSD	40	1553



CONSTRUCTION STANDARDS
PRIMARY 3 PHASE
METERING ENCLOSURE

REVISIONS			
DATE	ENGR	OPS	
2/23/00	HWH	MA	
8/2/05	LB	AH	

PAGE: 1 of 1	UM1	CAD FILE: UM1	APP: DATE: 9/94	SECTION 900
--------------	------------	---------------	-----------------	-------------

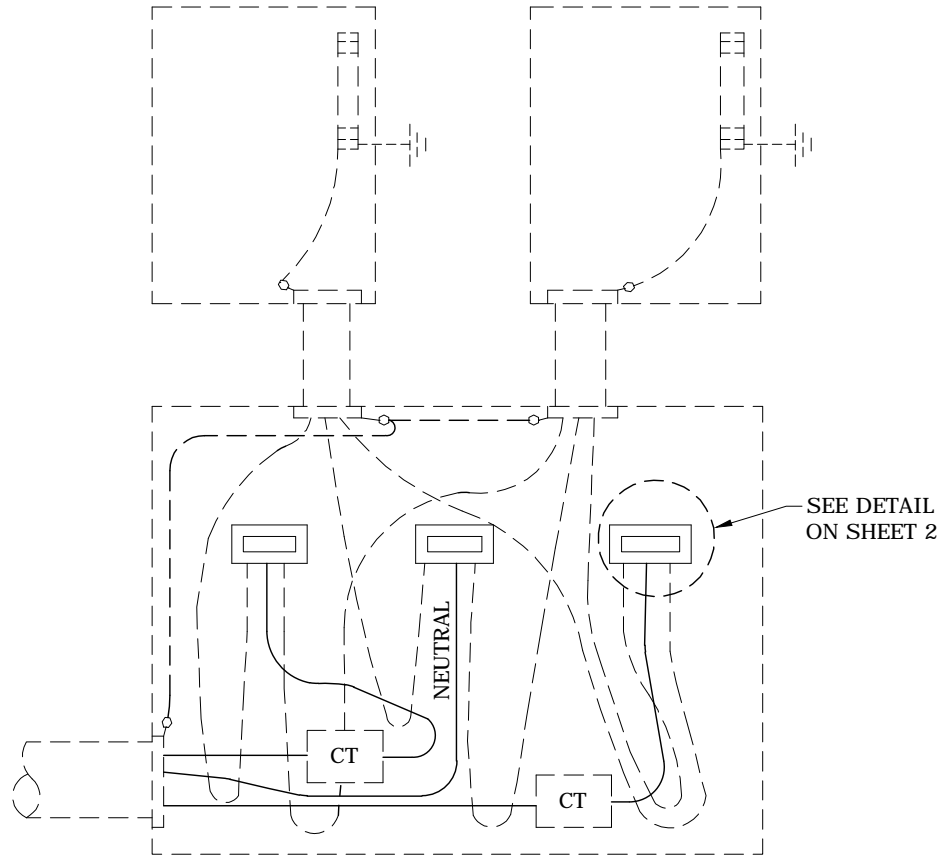

**C.T. CAN
FRONT VIEW**

NOTE: FOR CONDUCTORS 1/0 TO 350 KCM ALUMINUM

REV 1. NOTES FOLLOWED BY STAR HAVE BEEN REVISED

REV 2. REMOVED 3Ø FROM TITLE AND CORRECTED NOTE & MATERIAL ISSUE



CONSTRUCTION STANDARDS

SECONDARY 1Ø
CT METERING ASSEMBLIES
RESIDENTIAL

REVISIONS

△	DATE	ENGR	OPS
1	2/23/00	HWH	MA
2	8/2/05	LB	AH

PAGE:
1 of 2

UMS4, UMS6, UMS34, UMS36

CAD FILE:
UMS4

APP:
DATE: 9/94

SECTION
900

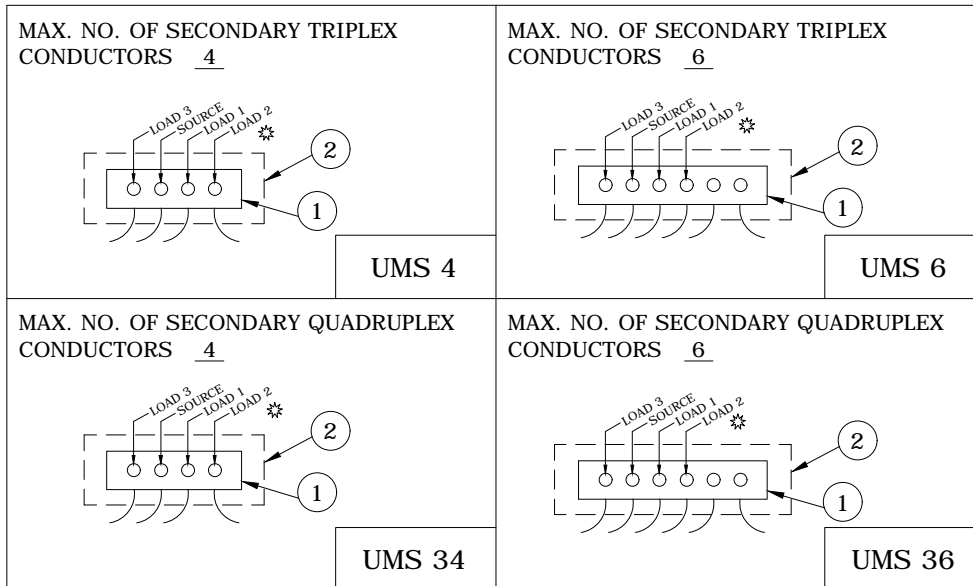

REV 2. REMOVED 3Ø FROM TITLE AND CORRECTED NOTE & MATERIAL ISSUE

ITEM NO.	DESCRIPTION	UMS4	
		QTY.	S/N
1	Connector, Pedestal 4	3	528
2	Cover, Connector	3	573 *
ITEM NO.	DESCRIPTION	UMS6	
		QTY.	S/N
1	Connector, Pedestal 6	3	531
2	Cover, Connector	3	574
ITEM NO.	DESCRIPTION	UMS34	
		QTY.	S/N
1	Connector, Pedestal 4	4	528
2	Cover, Connector	4	573 *
ITEM NO.	DESCRIPTION	UMS36	
		QTY.	S/N
1	Connector, Pedestal 6	4	531
2	Cover, Connector	4	574

	<h2>CONSTRUCTION STANDARDS</h2> <p>SECONDARY 1Ø CT METERING ASSEMBLIES RESIDENTIAL</p>			REVISIONS				
		DATE	ENGR	OPS				
	1	2/23/00	HWH	MA				
	2	8/2/05	LB	AH				
PAGE: 2 of 2		UMS4, UMS6, UMS34, UMS36		CAD FILE: UMS4		APP: _____ DATE: 9/94		SECTION 900